



Louder &
Brighter
since 1910.

AuerSignal

Louder & Brighter since 1910.

Since 1910, our driving force has been our desire to use exceptional engineering ingenuity to develop superior technical equipment that is a step ahead of the rest. This desire is now stronger than ever.

Although we are a medium-sized company, we have huge ambitions. As an owner-run family company, trust and compassion are at the heart of all we do.

Here at Auer Signal, we are passionate about upholding the image we have created for ourselves, working to the motto 'louder & brighter since 1910'.

A new corporate design for Auer Signal

We thought it was about time to give our corporate design and branding a bit of a revamp. The inspiration for our new logo was taken from the side view of a ventilator that my grandfather developed back in the 1960s – the new is very much born from the old.

Auer Signal proud to present new website

As well as redesigning this product catalogue, we have also given our website – www.auersignal.com – a fresh new look. Alongside the search function, there is now also a configurator tool for our signal tower series. Additional intelligent filters help you quickly find the exact product you need to suit your application or to ensure compliance with specifications. The wish list feature allows you to send article numbers, selected products and all of the available technical documents by email. You can also save them or print them all out together if you prefer.

Auer Signal is one of the world's leading manufacturers of signalling equipment

We are incredibly proud to be able to say this. We are constantly working to develop new products and have been keeping our customers happy with our innovation, foresight and trustworthiness since 1910. To make sure this does not change going forwards, both we and our signalling devices will continue to be: louder & brighter.



Christian Auer

- 1 Foreword
- 3 Contents
- 4 Why Auer Signal

6 Ex-Proof

8 INFORMATION EX-PROOF

10 VISUAL SIGNALLING

- 10 dSD Ex-Proof LED Signal Beacon
- 12 mDD Ex-Proof LED Signal Beacon
- 14 mMD Ex-Proof LED Multi Colour Signal Beacon
- 16 dSF Ex-Proof Xenon Strobe Beacon

18 AUDIBLE SIGNALLING

- 18 dMS Ex-Proof Multi-Tone Siren
- 20 mHPT Ex-Proof Signal Horn
- 22 mHTG Ex-Proof Signal Horn
- 24 dHH Ex-Proof Signal Horn
- 26 dHW Ex-Proof Signal Bell

28 Telephones

30 INFORMATION TELEPHONES

32 EX-PROOF

- 32 dST Ex-Proof Analogue Telephone
- 34 dST-MB Ex-Proof Analogue Telephone
- 36 dFT3 Ex-Proof Analogue Telephone
- 38 dST-IP Ex-Proof VoIP Telephone
- 42 dFT3-IP Ex-Proof VoIP Telephone

46 EX-PROOF ACCESSORIES

- 46 AS1 Ex-Proof Audible Telephone Call Signalling Sounder
- 48 VS1 Ex-Proof Visual-Audible Telephone Call Signalling Sounder
- 50 EP1 Ex-Proof Additional Earpiece
- 52 HS1 Ex-Proof Headset Kit
- 54 mTCR Ex-Proof Telephone Connecting Relay

56 WEATHERPROOF

- 56 wST Weatherproof Analogue Telephone
- 58 wST-MB Weatherproof Analogue Telephone
- 60 wFT3 Weatherproof Analogue Telephone
- 62 wIND Weatherproof Analogue Telephone
- 64 wST-IP Weatherproof VoIP Telephone
- 68 wFT3-IP Weatherproof VoIP Telephone
- 70 wIND-IP Weatherproof VoIP Telephone

72 WEATHERPROOF ACCESSORIES

- 72 VS2 Visual-Audible Telephone Call Signalling Sounder
- 74 IC Weatherproof Analogue Intercom Telephone
- 76 EP2 Additional Earpiece
- 78 HS2 Headset Kit
- 80 LS2 weather-proof loudspeaker set
- 82 TCR Weatherproof Telephone Connecting Relay
- 84 TH1 Telephone Protection Hoods
- 86 TH2 Telephone Protection Hoods

88 TECHNICAL INFORMATIONS

- 88 General technical informations
- 91 Ex-Proof
- 96 Type index
- 97 Item index

Seven compelling reasons to choose Auer Signal

1

WE DEVELOP OUR OWN PRODUCTS AND PRODUCTION IS COMPLETED TO THE HIGHEST OF INDUSTRIAL STANDARDS

All of the development work for our products is taken care of in-house – from the initial planning to the design stage.

We are most proud of our electronic development, with state-of-the-art industrial machines in use for production and innovative IT solutions ensuring that our production processes are continually optimised.

Thorough and detailed testing enables us to achieve optimum quality. We are particularly proud of our performance in electronic development.

2

EVERY PRODUCT WE CREATE IS OF EXCEPTIONAL QUALITY

We only use premium materials in our production processes and polycarbonate is one of our key resources, as it is impact-proof, UV-resistant and colour-fast.

We always ensure that our visual signalling equipment has an intelligent lens design and features state-of-the-art LED technology. To meet the highest of demands for signalling, we supply products with the most effective high-power LEDs available.

Our modular signal towers are created with the utmost precision, helping our company to stand out from the crowd by offering innovative detailed solutions. Audible signalling equipment from Auer Signal is among the loudest on the market.

3

WE HAVE PRODUCTS FOR EVERY APPLICATION – RANGING FROM THE PREMIUM TO THE VALUE SEGMENT

Our extensive product portfolio covers all of the requirements across our signalling equipment markets. As well as our high-end equipment, our range also includes some exciting products with an excellent price-performance ratio.

We offer our customers an extensive product portfolio that is tailored to specifications.

From automation technology, mechanical and plant engineering and building technology to the chemical and petrochemical sectors, safety applications and even uses under extreme conditions, we serve all sectors and branches of industry.

4

WE DEVELOP AND PRODUCE TAILOR-MADE SIGNALLING EQUIPMENT

Our ability to listen teamed with our engineers' passion for developing new products and special solutions to suit specific requirements has been key to our success.

With products being fully developed in-house, adjustments being made in line with a customer's own product design, and special wiring options and types of mounting, we are confident that we are the number one partner when it comes to implementing any customer requirements that are specific to them or their sector.

5

OUR SIGNALLING EQUIPMENT COMPLIES WITH THE REQUIRED INDUSTRY STANDARDS FOR USE AROUND THE WORLD

We live and breathe quality and safety standards. Plus, as Auer Signal is an international company, our signalling equipment is globally approved and can be used all around the world.

UL, EAC, CE, ATEX and ISO certifications make up the most important marks and safety standards for Auer signalling equipment.



6

WE KEEP OUR PROMISES (AND HAVE BEEN DOING SO SINCE 1910)

Auer Signal is an owner-run family company in its fourth generation.

We are a well-established company that has been a reliable partner for more than 100 years now.

For all of our customers and partners, our unwavering trustworthiness is a convincing selling point that they have come to value highly.

We have a dedicated team of highly skilled employees who are friendly and personable as they work quickly to see to our customers' every wish and desire. This is reflected in the international business relationships we have built up on trust and reliability, which are still standing after decades.

7

WE ALWAYS DELIVER ON TIME

We have an excellent record when it comes to delivering on time, meeting our deadlines in 99.7% of cases, working to a just-in-time supply system. Keeping our delivery promises belongs to our traditions and ensures that our customers are very satisfied and loyal.

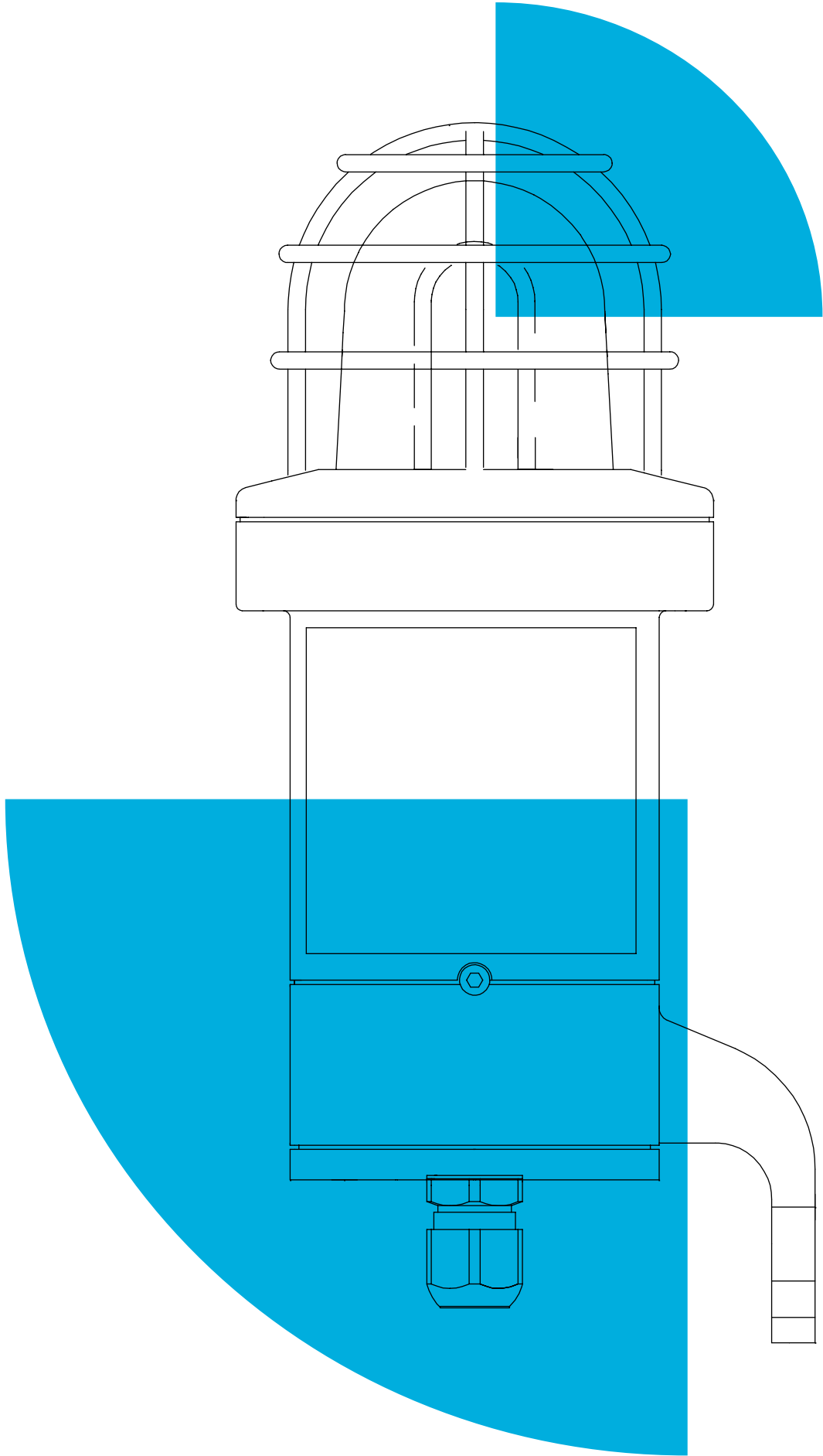



8 Information Ex-proof

10 Visual signalling

- 10 dSD Ex-Proof LED Signal Beacon
- 12 mDD Ex-Proof LED Signal Beacon
- 14 mMD Ex-Proof LED Multi Colour Signal Beacon
- 16 dSF Ex-Proof Xenon Strobe Beacon

18 Audible signalling

- 18 dMS Ex-Proof Multi-Tone Siren
- 20 mHPT Ex-Proof Signal Horn
- 22 mHTG Ex-Proof Signal Horn
- 24 dHH Ex-Proof Signal Horn
- 26 dHW Ex-Proof Signal Bell

EX signalling devices

Complete range of explosion-proof signalling devices for all industries in which combustible gases, vapours and dusts are created during the production process.



Extensive range of visual and audible explosion-protected signalling devices for use in potentially explosive gas and dust atmospheres classified as Zones 1 and 21. All products offer ignition protection type "e" (increased safety) and can be connected easily and cost-effectively.

EXPLOSION-PROOF**SIGNAL BEACONS**

- Available as steady/flashing/strobe/rotating beacons with ignition protection type "d" (flame-proof enclosure) or "m" (encapsulation) for Zone 1, 21
- With LED technology or classic xenon flashing technology
- High degree of protection IP66
- LED multi-colour beacon with 5 signalling colours and 3 signalling modes for Zone 2, 22

**EXPLOSION-PROOF SIGNAL****HORNS AND SIGNAL BELLS**

- In ignition protection type "d" (flame-proof enclosure), plastic housing, IP66 degree of protection, for Zone 1
- In ignition protection type "m" (encapsulation), in plastic or metal housings, IP54/66 degree of protection, for Zone 1, 21
- Classic horn tone with electromechanical horn system

EXPLOSION-PROOF MULTI-TONE**ALARM SOUNDERS**

- Multi-tone alarm sounders with 32 signal tones, 2 tones can be switched externally, adjustable volume
- In ignition protection type "d" (flame-proof enclosure), housing made from copper-free seawater-resistant aluminium, for Zone 1, 21
- High degree of protection IP66

EXPLOSION-PROOF VISUAL-**AUDIBLE SIGNALLING SOUNDER**

- Xenon strobe beacon with audible signalling sounder with ignition protection type "m" (encapsulation), for Zone 1
- For universal applications in potentially explosive industrial areas



dSD Explosion-proof LED signal beacon

- Certified for gas and dust hazardous areas of zone 1, 2, 21, 22
- Flame-proof enclosure "d"
- Terminal connection chamber "increased safety e"
- Housing made of copper-free seawater-resistant aluminium, hardened glass lens
- 5 LED colours, very good signalling effect
- All models with protection cage made of stainless steel

II 2 G Ex d e IIC T5, T6 Gb

II 2 D Ex tb IIIC T95 °C, T80 °C Db

-55 °C ≤ Ta ≤ +55 °C

Zone 1, 2, 21, 22



TECHNICAL DATA

Housing	Ø 110 mm, seawater-resistant aluminium, surface painted or powder-coated yellow/blue
Lens	tempered borosilicate glass,
Type of mounting	Bracket for wall mounting, any
Cable entry	Cable gland M20 × 1.5, sealing plug M20 × 1.5
Connection technology	1.5 mm ² fine wire and 2.5 mm ² single wire
Beacon type	LED steady beacon, LED flashing beacon, LED strobe beacon or LED all-round light
Light source	High Power LEDs
Luminous intensity	13–53 cd depending on colour
Speed of rotation	33/44 rpm switchable
Duty cycle	100 %
Operating temperature	-55 °C / +55 °C
Degree of protection	IP66 & IP67
Approval	PTB 03 ATEX 1230
Insulation class	III
Weight	2 kg

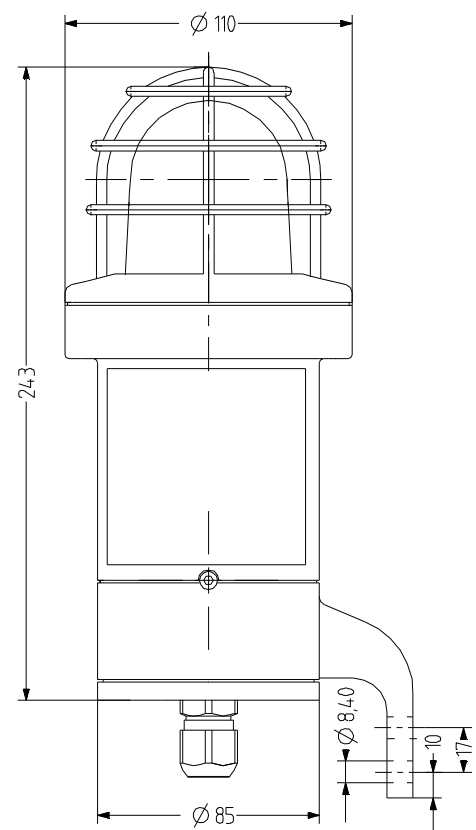

dSD

ORDER DATA

Type	Colour	Nominal voltage	Voltage range (V)	Nominal current (A)	Order number
dSD1	red	110-240 V AC	85-265	0,060-1,800	335 212 313
	blue	110-240 V AC	85-265	0,060-1,800	335 215 313
	green	110-240 V AC	85-265	0,060-1,800	335 216 313
	yellow	110-240 V AC	85-265	0,060-1,800	335 217 313
	clear	110-240 V AC	85-265	0,060-1,800	335 214 313
dSD2	red	24 V DC	+/- 20 %	0,190-1,600	335 212 005
		48 V DC	43-53	0,115-0,650	335 212 008
	blue	24 V DC	+/- 20 %	0,190-1,600	335 215 005
		48 V DC	43-53	0,115-0,650	335 215 008
	green	24 V DC	+/- 20 %	0,190-1,600	335 216 005
		48 V DC	43-53	0,115-0,650	335 216 008
	yellow	24 V DC	+/- 20 %	0,190-1,600	335 217 005
		48 V DC	43-53	0,115-0,650	335 217 008
clear	24 V DC	+/- 20 %	0,190-1,600	335 214 005	



MPL

ACCESSORIES

Type	Type of accessory	Order number
MPL	Mounting plate including explosion-proof junction box	335 500 000

mDD Explosion-proof LED signal beacon

- Certified for gas and dust hazardous areas of zone 1, 2, 21, 22
- Encapsulation "m"
- Polycarbonate plastic housing
- mounting bracket V4A

- 5 LED colours
- Degree of protection IP 66
- Protection class II (AC) or III (DC)
- Terminal connection chamber "increased safety e"

II 2 G Ex e mb (ib) IIC T4

II 2 D Ex mbD tD A21 IP 66 T130 °C

-40 °C ≤ Ta ≤ +60 °C (AC-Mod.)

-40 °C ≤ Ta ≤ +65 °C (DC-Mod.)

Zone 1, 2, 21, 22



TECHNICAL DATA

Housing	Ø 103 mm, Polycarbonate black (RAL 9005)
Lens	Polycarbonate, clear
Type of mounting	Bracket for wall mounting, V4A, any
Cable entry	Cable gland M20 × 1.5, 2× blind plugs M20 × 1.5
Connection technology	bis 2,5 mm ²
Beacon type	LED steady beacon, LED flashing beacon, LED strobe beacon or LED all-round light
Light source	LEDs
Luminous intensity	14 Cd (rot)
Duty cycle	100 %
Operating temperature	-40 °C / +60 °C
Degree of protection	IP66
Weight	2,5 kg

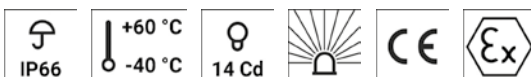
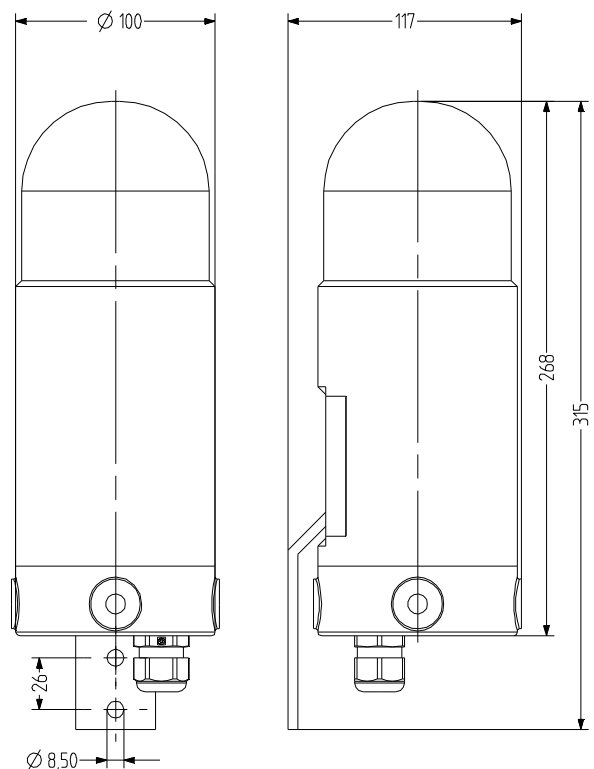

mDD

ORDER DATA

Type	Lens colour	Colour	Nominal voltage	Voltage range (V)	Nominal current (A)	Order number
mDD1	clear	red	230 V AC	+/- 20 %	0,035-0,047	336 002 413
		white	230 V AC	+/- 20 %	0,037-0,055	336 004 413
		blue	230 V AC	+/- 20 %	37-55	336 005 413
		green	230 V AC	+/- 20 %	0,037-0,055	336 006 413
		yellow	230 V AC	+/- 20 %	0,035-0,047	336 007 413
mDD2	clear	red	24 V DC	+/- 20 %	0,24-0,85	336 002 005
		white	24 V DC	+/- 20 %	0,32-1,28	336 004 005
		blue	24 V DC	+/- 20 %	0,31-1,25	336 005 005
		green	24 V DC	+/- 20 %	0,31-1,2	336 006 005
		yellow	24 V DC	+/- 20 %	0,24-0,9	336 007 005



MPL

ACCESSORIES

Type	Type of accessory	Order number
MPL	Mounting plate including explosion-proof junction box	335 500 000

mMD Explosion-proof LED multi colour beacon

- 5 signal colours and 3 operating modes, can be switched
 - steady/flashing/strobe light
- Certified for gas and dust hazardous areas of zone 2, 22
- Polycarbonate plastic housing
- Mounting bracket V4A
- Degree of protection IP 66
- Protection class II (AC) or III/II (DC)

II 3 G Ex nR IIC T6 Gc

II 3 D Ex tc IIIIC T85 °C Dc

-20 °C ≤ Ta ≤ +50 °C

Zone 2, 22



TECHNICAL DATA

Housing	Ø 103 mm, Polycarbonate black
Colours	green, yellow, red, blue, clear
Lens	Polycarbonate, clear
Type of mounting	Mounting bracket, any
Cable entry	Cable gland M20 × 1.5
Connection technology	bis 2,5 mm ²
Beacon type	LED steady beacon, LED flashing beacon or LED strobe beacon
Light source	LEDs
Duty cycle	100 %
Operating temperature	-20 °C / +50 °C
Degree of protection	IP66
Weight	1,4 kg

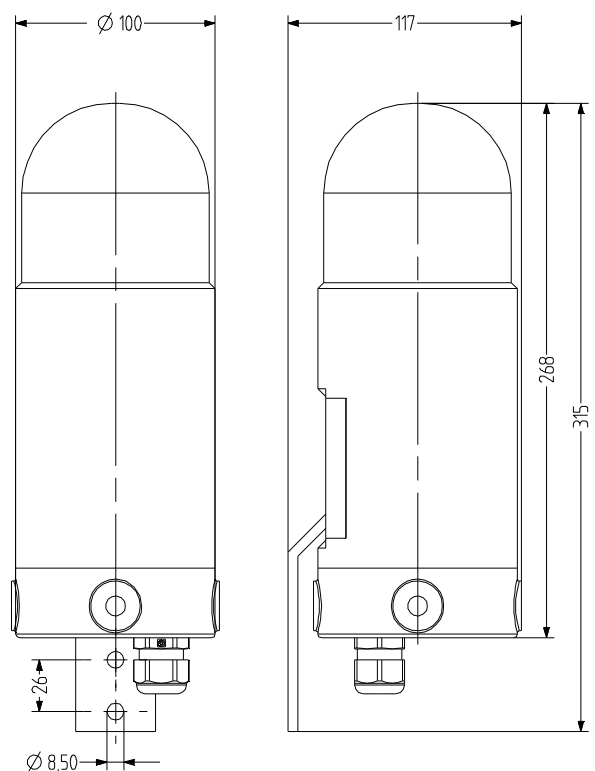

mMD

ORDER DATA

Lens colour	Nominal voltage	Voltage range (V)	Nominal current (A)	Order number
clear	24 V DC	+/- 20 %	<0,135	337 000 005
	230 V AC	+/- 20 %	<0,050	337 000 313



MPL

ACCESSORIES

Type	Type of accessory	Order number
MPL	Mounting plate including explosion-proof junction box	335 500 000

dSF Explosion-proof Xenon strobe beacon

- Xenon strobe beacon with 15 J or 5 J strobe energy
- Certified for gas and dust hazardous areas of zone 1, 2, 21, 22
- Flame-proof enclosure "d"
- Terminal connection chamber "increased safety e"
- Housing made of copper-free seawater-resistant aluminium
- Hardened glass lens
- 5 lens colours
- Degree of protection IP 66, protection class I
- All models with protection cage made of stainless steel

II 2 G Ex d e IIC T5, T6 Gb
 II 2 D Ex tb IIIC T95 °C, T80 °C Db
 -55 °C ≤ Ta ≤ +55 °C T5
 -55 °C ≤ Ta ≤ +40 °C T6
 Zone 1, 2, 21, 22



TECHNICAL DATA

Housing	Ø 110 mm, Aluminium, surface painted or powder-coated yellow/blue
Lens	tempered borosilicate glass, orange, red, clear, blue or green
Type of mounting	Bracket for wall mounting, any
Cable entry	1x cable gland M20 x 1.5, 1x sealing plug M20 x 1.5
Connection technology	1.5 mm ² fine wire and 2.5 mm ² single wire
Beacon type	Xenon strobe beacon
Light source	Xenon tube
Luminous intensity	5 J strobe energy/15 J strobe energy
Duty cycle	100 %
Service life	Light source: 5 million flashes
Operating temperature	-55 °C / +55 °C (T5) -55 °C / +40 °C (T6)
Degree of protection	IP66
Approval	PTB 03 ATEX 1230
Insulation class	I
Weight	2 kg

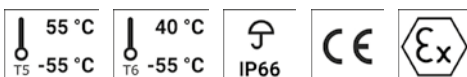
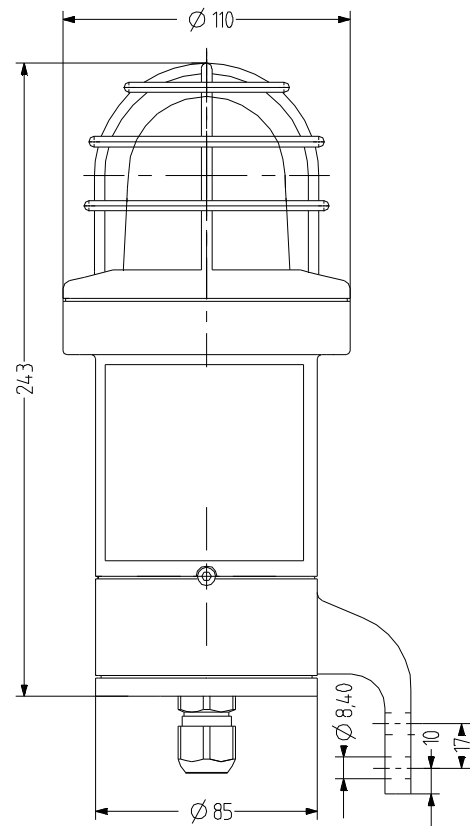

dSF

ORDER DATA

Type	Output	Lens colour	Nominal voltage	Voltage range (V)	Nominal current (A)	Order number	
dSF1	15 J	orange	110-120 V AC	103-127	0,135	335 001 410	
			230-240 V AC	207-253	0,200	335 001 413	
		red	110-120 V AC	103-127	0,135	335 002 410	
			230-240 V AC	207-253	0,200	335 002 413	
		clear	110-120 V AC	103-127	0,135	335 004 410	
			230-240 V AC	207-253	0,200	335 004 413	
	blue	110-120 V AC	103-127	0,135	335 005 410		
		230-240 V AC	207-253	0,200	335 005 413		
	green	110-120 V AC	103-127	0,135	335 006 410		
		230-240 V AC	207-253	0,200	335 006 413		
	5 J	orange	110-120 V AC	103-127	0,135	335 101 410	
			230-240 V AC	207-253	0,130	335 101 413	
		red	110-120 V AC	103-127	0,135	335 102 410	
			230-240 V AC	207-253	0,130	335 102 413	
		clear	110-120 V AC	103-127	0,135	335 104 410	
			230-240 V AC	207-253	0,130	335 104 413	
		blue	110-120 V AC	103-127	0,135	335 105 410	
			230-240 V AC	207-253	0,130	335 105 413	
green		110-120 V AC	103-127	0,135	335 106 410		
		230-240 V AC	207-253	0,130	335 106 413		
dSF2		15 J	orange	24 V DC	21-53	1,000	335 001 005
				80 V DC	72-132	0,250	335 001 009
	red		24 V DC	21-53	1,000	335 002 005	
			80 V DC	72-132	0,250	335 002 009	
	clear		24 V DC	21-53	1,000	335 004 005	
			80 V DC	72-132	0,250	335 004 009	
	blue		24 V DC	21-53	1,000	335 005 005	
			80 V DC	72-132	0,250	335 005 009	
	green		24 V DC	21-53	1,000	335 006 005	
			80 V DC	72-132	0,250	335 006 009	
	5 J		orange	24 V DC	21-53	0,280	335 101 005
				80 V DC	72-132	0,090	335 101 009
		red	24 V DC	21-53	0,280	335 102 005	
			80 V DC	72-132	0,090	335 102 009	
		clear	24 V DC	21-53	0,280	335 104 005	
			80 V DC	72-132	0,090	335 104 009	
		blue	24 V DC	21-53	0,280	335 105 005	
			80 V DC	72-132	0,090	335 105 009	
		green	24 V DC	21-53	0,280	335 106 005	
			80 V DC	72-132	0,090	335 106 009	



MPL

ACCESSORIES

Type	Type of accessory	Order number
MPL	Mounting plate including explosion-proof junction box	335 500 000

dMS Explosion-proof multi-tone alarm sounder

- Loud, explosion-proof electronic multi-tone alarm sounder
- Certified for gas and dust hazardous areas of zone 1, 2, 21, 22
- Flame-proof enclosure "d"
- Terminal connection chamber "increased safety e"
- 32 signal tones, 2 tones can be switched externally
- Housing made of copper-free seawater-resistant aluminium, black plastic sound protection hood
- Degree of protection IP 66
- Maximum sound pressure 115 dB (A) in 1 m
- Volume can be reduced in 3 steps of 10 dB each
- Protection class I, wide voltage range

II 2 G Ex d e IIB + H2 T6 Gb

II 2 D Ex tb IIIC T85° Db

-50 °C ≤ Ta ≤ +60 °C

Zone 1, 2, 21, 22



TECHNICAL DATA

Housing	copper-free, seawater-resistant aluminium yellow/blue, sound protection hood Polyamide black
Type of mounting	Bracket for wall mounting, Sound outlet opening at bottom
Cable entry	M20 × 1.5 (5.5–13 mm)
Connection technology	bis 2,5 mm ²
Power consumption	max. 14 W
Tone	32 Tones, 2 Tones can be switched externally, see tone table
Volume	115 dB (can be adjusted with DIP switch)
Duty cycle	100 %
Operating temperature	-50 °C / +60 °C
Degree of protection	IP66
Approval	PTB 14 ATEX 1005
Insulation class	I
Weight	2,8 kg

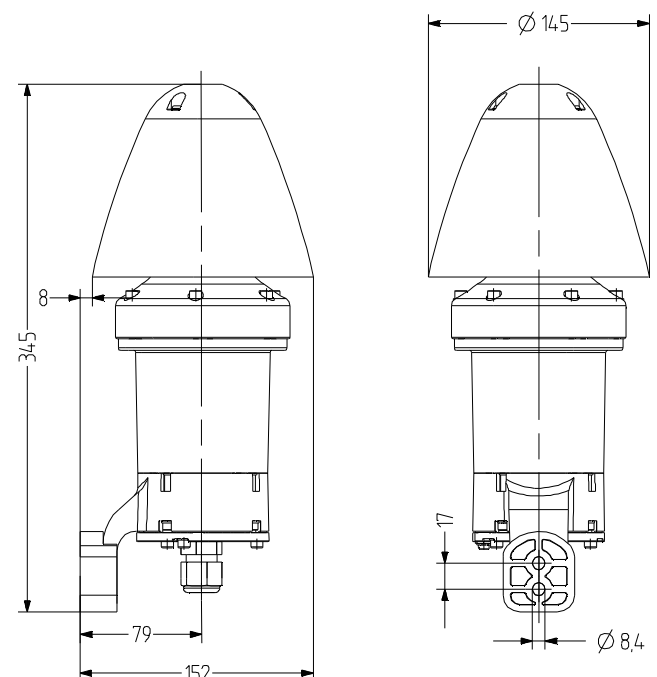

dMS

ORDER DATA

Type	Nominal voltage	Voltage range (V)	Nominal current (A)	Order number
dMS1	85-265 V AC	+/- 10 %	0,093	371 000 313
dMS2	24 V DC	+/- 10 %	0,460	371 000 005



MPL

ACCESSORIES

Type	Type of accessory	Order number
MPL	Mounting plate including explosion-proof junction box	335 500 000

mHPT Explosion-proof signal horn

- Loud, well-designed, explosion-proof electromechanical signal horn with typical horn tone
- Certified for gas hazardous areas of zone 1, 2
- Encapsulation
- Impact-resistant polycarbonate housing
- Degree of protection IP 54
- Insulation class II
- Available in all standard supply voltages
- Max. 108 dB (A) in 1 m

II 2 G Ex e mb II T5

-20 °C ≤ Ta ≤ +50 °C (AC-Mod.)

-20 °C ≤ Ta ≤ +60 °C (DC-Mod.)

Zone 1, 2



TECHNICAL DATA

Housing	Polycarbonate black (RAL 9005)
Type of mounting	Sound outlet opening at bottom
Cable entry	Cable entry M20 × 1.5
Connection technology	bis 2,5 mm ²
Tone	typical signal horn tone
Volume	108 dB
Duty cycle	75 %
Operating temperature	-20 °C / +60 °C-20 °C / +60 °C (DC) -20 °C / +50 °C (AC)
Degree of protection	IP54
Insulation class	II
Weight	500 g
Drive system	non-polarised electromagnet, tappet strikes the membranes between 100 and 120 times/sec; DC with electrical contact breaker

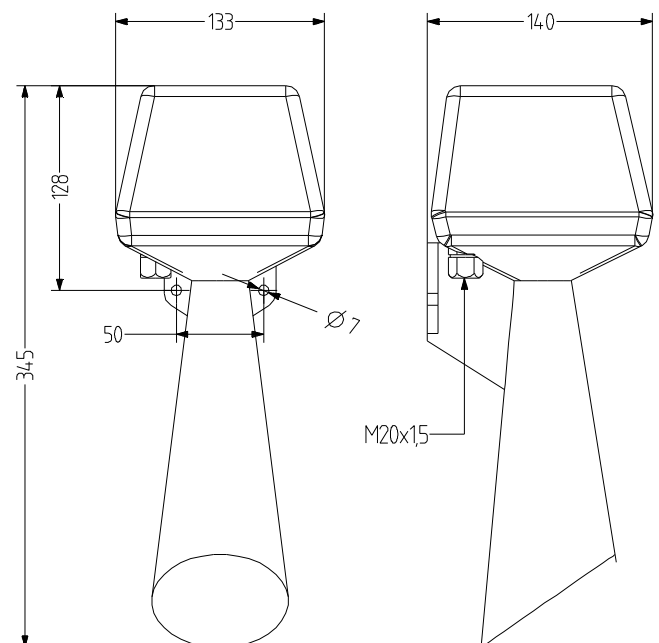

mHPT

ORDER DATA

Nominal voltage	Voltage range (V)	Nominal current (A)	Order number
24 V DC	+ 10 %/- 15 %	0,300	301 100 005
115 V AC	+ 10 %/- 15 %	0,150	301 100 110
230 V AC	+ 10 %/- 15 %	0,070	301 100 113



mHTG Explosion-proof signal horn

- Loud, well-designed, explosion-proof electromechanical signal horn with typical horn tone
- Certified for gas and dust hazardous areas of zone 1, 2, 21, 22
- Encapsulation
- Die-cast aluminium housing
- Weather-proof paint, resistant to seawater
- Degree of protection IP 66
- Insulation class I
- Max. 108 dB (A) in 1 m

II 2 G Ex e mb II T5
 II 2 D Ex tD A21 IP66 T90°C
 -55 °C ≤ Ta ≤ +50°C (AC-Mod.)
 -55 °C ≤ Ta ≤ +60°C (DC-Mod.)
 Zone 1, 2, 21, 22



TECHNICAL DATA

Housing	seawater-resistant aluminium, with weather-proof paint grey
Type of mounting	Sound outlet opening at bottom
Cable entry	Cable gland M20 × 1.5
Connection technology	bis 2,5 mm ²
Tone	typical signal horn tone
Volume	max. 108 dB
Duty cycle	75 %
Operating temperature	-55 °C / +60 °C (DC) -55 °C / +50 °C (AC)
Degree of protection	IP66
Insulation class	I
Weight	2 kg
Drive system	non-polarised electromagnet, tappet strikes the membranes between 100 and 120 times/sec; DC with electrical contact breaker

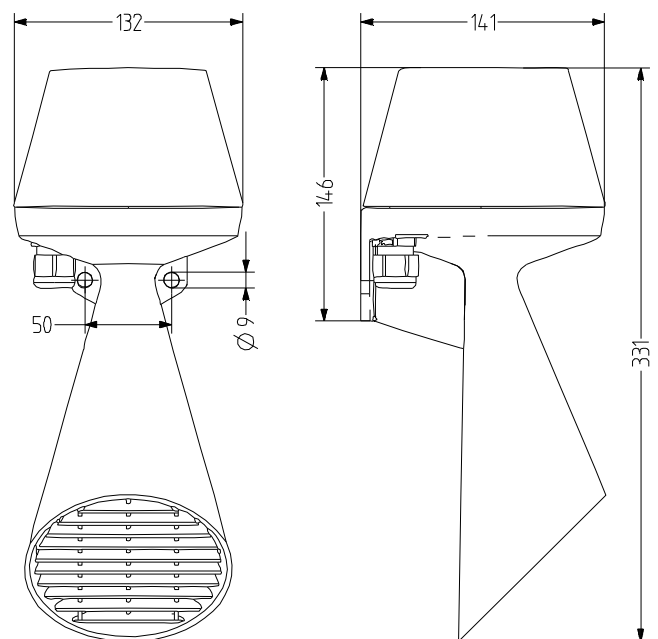

mHTG

ORDER DATA

Nominal voltage	Voltage range (V)	Nominal current (A)	Order number
24 V DC	+ 10 %/- 15 %	0,300	302 100 005
230 V AC	+ 10 %/- 15 %	0,070	302 100 113



dHH Explosion-proof signal horn

- Loud, explosion-proof electromechanical signal horn with a typical horn tone
- Certified for use in gas and dust hazardous areas of zone 1, 2, 21, 22
- Flame-proof enclosure "d"
- Terminal connection chamber "increased safety e"
- Housing made of glass-fibre-reinforced plastic
- Degree of protection IP 66, max. 105 dB (A) in 1 m
- Protection class II, no equipotential bonding required
- robust design
- Model with integrated telephone-call current relay available

II 2 G Ex d e IIC T5, T6 Gb

II 2 D Ex tb IIIC T95 °C, T80 °C Db

-20 °C ≤ Ta ≤ +75 °C T5

-20 °C ≤ Ta ≤ +70 °C T6

Zone 1, 2, 21, 22



TECHNICAL DATA

Housing	Ø 190 mm, glass-fibre-reinforced polyester black (RAL 9005)
Type of mounting	any with rotatable bracket mounting, sound outlet preferably at front or bottom
Cable entry	1× cable gland M20 × 1.5, 1× sealing plug M20 × 1.5
Connection technology	1.5 mm ² fine wire and 2.5 mm ² single wire
Tone	Steady tone
Volume	max. 105 dB
Duty cycle	100 %
Operating temperature	-20 °C / +75 °C [T5] -50 °C / +70 °C [T6]
Degree of protection	IP66
Approval	PTB 01 ATEX 1133
Insulation class	II
Weight	5,5 kg

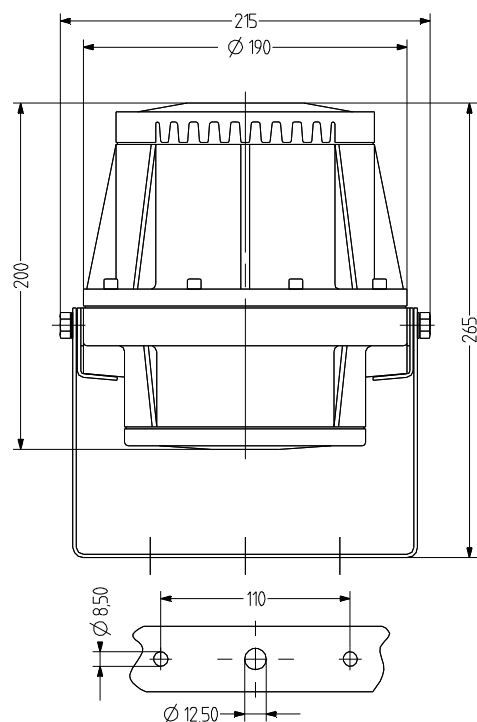

dHH**ORDER DATA**

Type	Nominal voltage	Voltage range (V)	Nominal current (A)	Telephone call current relay	Order number
dHH	12 V AC	+ 10 %/- 15 %	1,200		300 000 104
	12 V DC	+ 10 %/- 15 %	0,600		300 000 004
	24 V DC	+ 10 %/- 15 %	0,300		300 000 005
	24 V AC	+ 10 %/- 15 %	0,650		300 000 105
	42 V AC	+ 10 %/- 15 %	0,300		300 000 107
	48 V DC	+ 10 %/- 15 %	0,170		300 000 008
	48 V AC	+ 10 %/- 15 %	0,350		300 000 108
	60 V AC	+ 10 %/- 15 %	0,250		300 000 109
	60 V DC	+ 10 %/- 15 %	0,150		300 000 009
	110 V DC	+ 10 %/- 15 %	0,080		300 000 010
	110 V AC	+ 10 %/- 15 %	0,150		300 000 110
	120 V AC	+ 10 %/- 15 %	0,150		300 000 211
	220 V DC	+ 10 %/- 15 %	0,050		300 000 013
	230 V AC	+ 10 %/- 15 %	0,070		300 000 113
	240 V AC	+ 10 %/- 15 %	0,070		300 000 213
dHHR	230 V AC	+ 10 %/- 15 %	0,070	with telephone call current relay	300 100 113



dHW Explosion-proof signal bell

- Loud, explosion-proof electromechanical signal horn with a typical bell tone
- Certified for use in gas and dust hazardous areas of zone 1, 2, 21, 22
- Flame-proof enclosure "d"
- Terminal connection chamber "increased safety e"
- Housing made of glass-fibre-reinforced plastic
- Degree of protection IP 66, max. 105 dB (A) in 1 m
- Protection class II, no equipotential bonding required
- robust design
- Model with integrated telephone-call current relay available

II 2 G Ex de IIC T6

II 2 D Ex tD A21 IP66 T80°C

-20 °C ≤ Ta ≤ +40 °C

Zone 1, 2, 21, 22



TECHNICAL DATA

Housing	Ø 200 mm, glass-fibre-reinforced polyester black (RAL 9005)
Type of mounting	any with rotatable bracket mounting, sound outlet preferably at front or bottom
Cable entry	1× cable gland M20 × 1.5, 1× M20 × 1.5 with sealing plug
Connection technology	1.5 mm ² fine wire and 2.5 mm ² single wire
Tone	1 Tones, typical bell tone
Volume	max. 105 dB
Duty cycle	100 %
Operating temperature	-20 °C / +40 °C
Degree of protection	IP66
Approval	PTB 01 ATEX 1134
Insulation class	II
Weight	5,5 kg

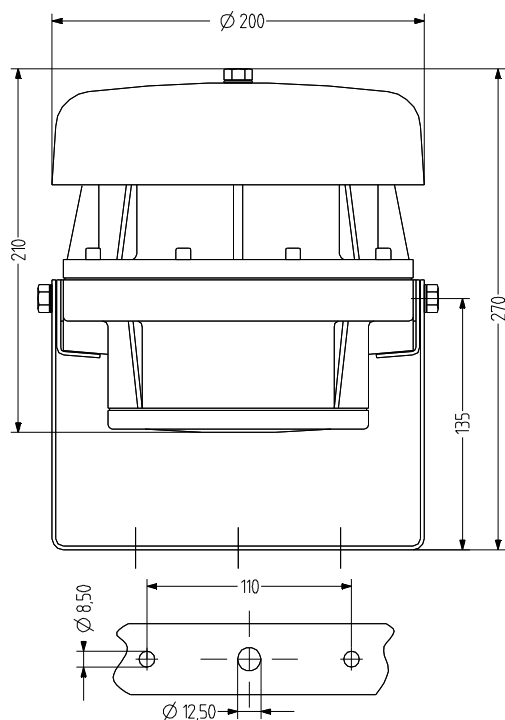

dHW

ORDER DATA

Type	Nominal voltage	Voltage range (V)	Nominal current (A)	Telephone call current relay	Order number
dHW1	12 V AC	+ 10 %/- 15 %	0,600		320 000 104
	24 V AC	+ 10 %/- 15 %	0,320		320 000 105
	48 V AC	+ 10 %/- 15 %	0,300		320 000 108
	60 V AC	+ 10 %/- 15 %	0,240		320 000 109
	110 V AC	+ 10 %/- 15 %	0,140		320 000 110
	120 V AC	+ 10 %/- 15 %	0,180		320 000 211
	230 V AC	+ 10 %/- 15 %	0,055		320 000 113
	240 V AC	+ 10 %/- 15 %	0,065		320 000 213
dHW2	12 V DC	+ 10 %/- 15 %	0,600		320 000 004
	24 V DC	+ 10 %/- 15 %	0,350		320 000 005
	48 V DC	+ 10 %/- 15 %	0,300		320 000 008
	60 V DC	+ 10 %/- 15 %	0,230		320 000 009
	110 V DC	+ 10 %/- 15 %	0,130		320 000 010
	220 V DC	+ 10 %/- 15 %	0,070		320 000 013
dHWR1	230 V AC	+ 10 %/- 15 %	0,055	with telephone call current relay	320 100 113



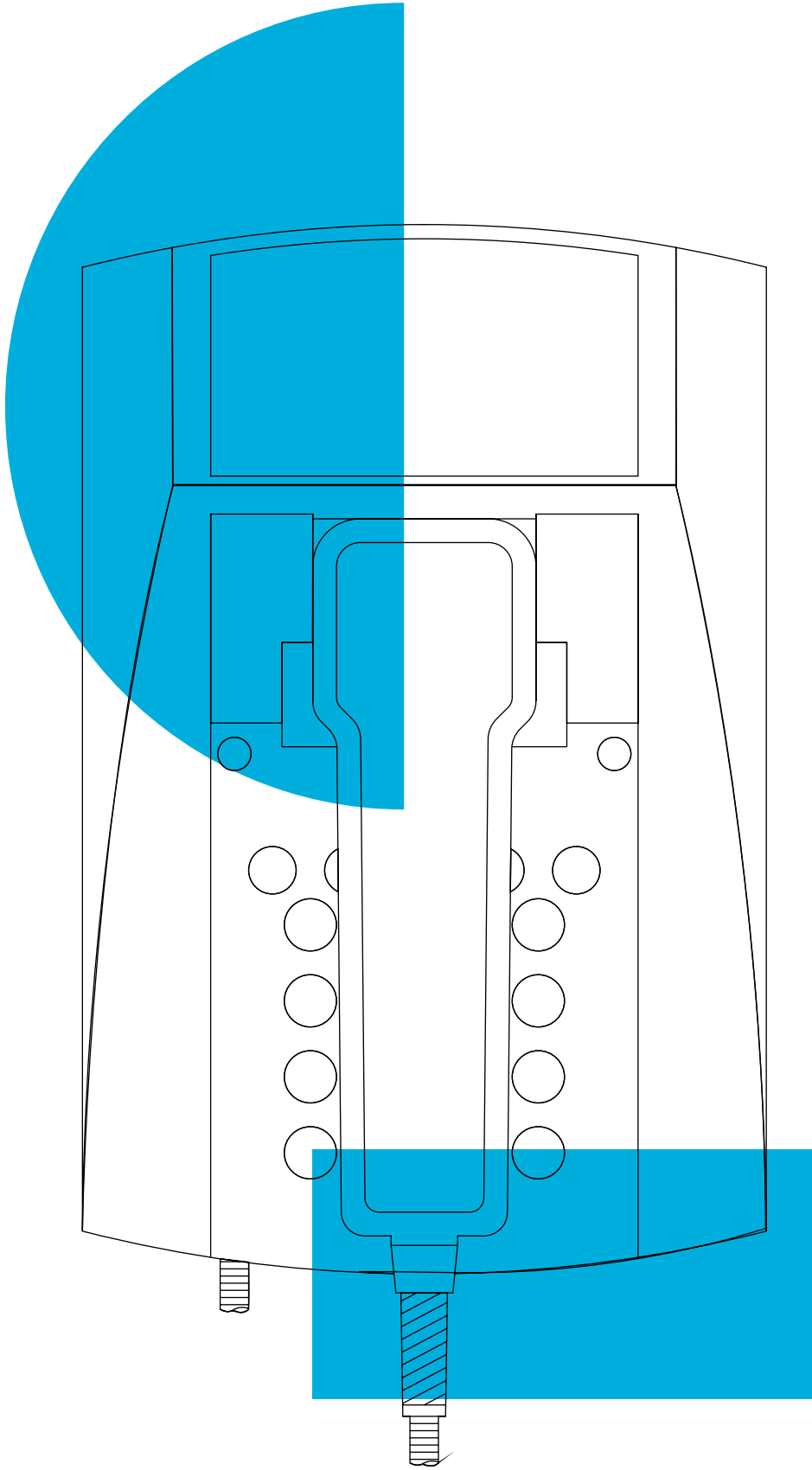

Telephones

30 Information Telephones

32 Ex-Proof

- 32 dST Ex-Proof Analogue Telephone
- 34 dST-MB Ex-Proof Analogue Telephone
- 36 dFT3 Ex-Proof Analogue Telephone
- 38 dST-IP Ex-Proof VoIP Telephone
- 42 dFT3-IP Ex-Proof VoIP Telephone

46 Ex-Proof Accessories

- 46 AS1 Ex-Proof Audible Telephone Call Signalling Sounder
- 48 VS1 Ex-Proof Visual-Audible Telephone Call Signalling Sounder
- 50 EP1 Ex-Proof Additional Earpiece
- 52 HS1 Ex-Proof Headset Kit
- 54 mTCR Ex-Proof Telephone Connecting Relay

56 weatherproof

- 56 wST Weatherproof Analogue Telephone
- 58 wST-MB Weatherproof Analogue Telephone
- 60 wFT3 Weatherproof Analogue Telephone
- 62 wIND Weatherproof Analogue Telephone
- 64 wST-IP Weatherproof VoIP Telephone
- 68 wFT3-IP Weatherproof VoIP Telephone
- 70 wIND-IP Weatherproof VoIP Telephone

72 weatherproof Accessories

- 72 VS2 Visual-Audible Telephone Call Signalling Sounder
- 74 IC Weatherproof Analogue Intercom Telephone
- 76 EP2 Additional Earpiece
- 78 HS2 Headset Kit
- 80 LS2 weather-proof loudspeaker set
- 82 TCR Weatherproof Telephone Connecting Relay
- 84 TH1 Telephone Protection Hoods
- 86 TH2 Telephone Protection Hoods



Telephones

Complete range of explosion-proof and weather-proof telephones. With analogue and VoIP technology for all kinds of industrial requirements – both offshore and onshore.





Two explosion-proof telephone groups for Zone 1 and 21 and for Zone 2 and 22. Highly robust with up to IK09 impact protection.

FEATURES

- Certified for potentially explosive gas and dust atmospheres classified as Zone 1 and 21 or Zone 2 and 22
- High impact protection up to IK09
- Models with analogue and VoIP technology
- Maximum resistance to adverse ambient conditions (humidity, acids, alkalis, temperatures, etc.)
- IP66/IP65 degree of protection
- Extensive range of telephone accessories: audible and visual-audible secondary signalling sounder, headsets and additional earpiece sets, telephone protection hoods, telephone connecting relays

dST Explosion-proof analogue telephone

- Certified for gas and dust hazardous areas – zone 1, 2, 21, 22
- Degree of protection IP 66 & impact resistance IK09
- Very robust weather-proof housing with steel-armoured handset cord to withstand high tensile forces
- For demanding industrial, onshore and offshore applications
- V4A steel keypad, designed for use with gloves
- Easily readable alphanumerical display
- Freely programmable, housing colours black and red
- Version without keypad/display available as emergency telephone



II 2 G Ex e mb [ib] IIC T6/T5 Gb
 II 2 D tb [ib] IIIC T80°C/T100 °C Db
 -25 °C ≤ Ta ≤ +40 °C/+60 °C
 Zone 1, 2, 21, 22

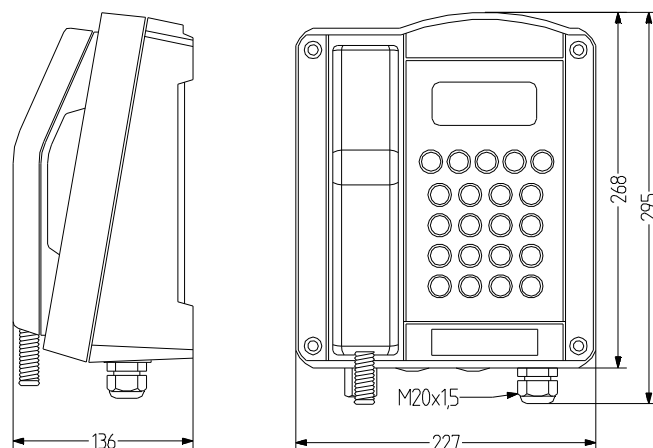

TECHNICAL DATA

Dialling method	PD DTMF operation can be selected from menu DTMF operation as per CCITT recommendation Q.23 PD operation with pulse/pause ratio of 1.5:1 or 2:1, which can be selected via menu navigation
Tone ringing volume	90 dB At 1 m
Transportation/storage temperature	-25°C/+70°C
Housing	glass-fibre-reinforced polyester red or black
Cable entry	1× M20 × 1.5, 2× blind plugs M20 × 1.5
Connection technology	up to 4 mm ² rigid, up to 2.5 mm ² flexible
Operating temperature	-25°C bis +60°C (T5) -25°C bis +40°C (T6)
Degree of protection	IP66
Impact resistance	IK09
Approval	DMT 03 ATEX E034
Technology	analogue
Keypad	Metal keypad with ice protection 21 keys with ABC lettering for name entries

Noise suppression	> 3 dB thanks to integrated mouthpiece horn
Supply voltage	24 V DC-66 V DC
Supply current	0,015 A DC-0,10 A DC
Ringling alternating current	24 V AC-90 V AC (at 21-54 Hz ringing frequency) 30 V AC-90 V AC (at 16.6-54 Hz ringing frequency)
Tone ringing impedance	> 6.0 KΩ at 25 Hz and 24-90 V AC > 4.0 KΩ at 50 Hz and 24-90 V AC
Enquiry key	Flash function can be adjusted from 40 ms-399 ms
W conductor	Option to connect external call signalling sounder
Weight	5,5 kg
Display	2-line alphanumerical display with pictograms, visible area 78 × 26 mm
Mouthpiece	Electret microphone
Receiver	dynamic receiver with leakage field spool for inductively coupling hearing aids
Stabiliser bracket	integrated, adjustable stabiliser protection
Handset cord	steel-reinforced armoured cord made of V4A



dST

ORDER DATA

Type	Keypad	Display	Housing colour	
			black	red
dST1	with keypad	with display	410 010 000	410 010 100
dST2	without keypad	without display	410 020 000	410 020 100



AS1



VS1



EP1



HS1



mTCR



TH1



TH2

ACCESSORIES

Type	Type of accessory	Colour	Housing material	Weight	Order number		
AS1	Explosion-proof audible telephone call signalling sounder			500 g	410 100 004		
VS1	Explosion-proof visual-audible signalling sounder	black (RAL 9005)orange		1,42 kg	410 101 005		
		black (RAL 9005)red		1,42 kg	410 102 005		
		black (RAL 9005)clear		1,42 kg	410 104 005		
		black (RAL 9005)blue		1,42 kg	410 105 005		
		black (RAL 9005)green		1,42 kg	410 106 005		
EP1	Explosion-proof additional earpiece set			200 g	410 100 002		
HS1	Headset kit			1,33 kg	410 100 001		
mTCR	Explosion-proof telephone connecting relay			1,1 kg	410 100 100		
TH1	Telephone sound protection hood	yellow (RAL 1023)	PVC – plastic (UV and weather-resistant)	30 kg	410 100 012		
			glass-fibre-reinforced plastic (GFRP)	40 kg	410 100 008		
			Console (sheet steel, powder-coated)	17 kg	410 100 011		
			Metal	35 kg	410 100 006		
			red (RAL 3020)	PVC – plastic (UV and weather-resistant)	30 kg	410 100 014	
				glass-fibre-reinforced plastic (GFRP)	40 kg	410 100 015	
		Metal		35 kg	410 100 009		
		orange (RAL 2000)		PVC – plastic (UV and weather-resistant)	30 kg	410 100 013	
				glass-fibre-reinforced plastic (GFRP)	40 kg	410 100 007	
		Stainless steel		Stainless steel	40 kg	410 100 010	
		TH2	Telephone sound protection hood	yellow	Stainless steel	3,5 g	410 100 020
					PVC – plastic (UV and weather-resistant)	3,5 g	410 100 030



dST-MB Explosion-proof analogue telephone

- Explosion-proof analogue telephone
- Certified for gas and dust hazardous areas – zone 1/21
- Degree of protection IP 66
- Very robust weather-proof housing with steel-armoured handset cord to withstand high tensile forces
- Impact protection IK09
- For demanding industrial, onshore and offshore applications
- V4A steel keypad, designed for use with gloves
- 3 freely programmable memory buttons for quick dialling
- Freely programmable, housing colour black
- Convenient telephone functions



II 2 G EEx mb[ib] IIC T6/T5 Gb
 II 2 D IP66 IIIC T80 °C / T100 °C Db
 -25 °C ≤ Ta ≤ +40 °C/+60 °C
 Zone 1, 2, 21, 22

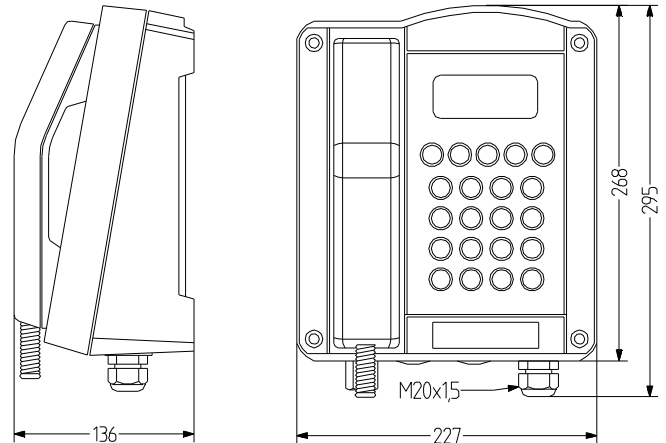

TECHNICAL DATA

Dialling method	PD DTMF operation can be selected from menu DTMF operation as per CCITT recommendation Q.23 PD operation with pulse/pause ratio of 1.5:1 or 2:1, which can be selected via menu navigation
Tone ringing volume	90 dB
Transportation/storage temperature	-25 °C / +70 °C
Housing	glass-fibre-reinforced polyester black (RAL 9005)
Cable entry	1× M20 × 1.5, 2× blind plugs M20 × 1.5
Connection technology	up to 4 mm ² rigid, up to 2.5 mm ² flexible
Degree of protection	IP66
Impact resistance	IK09
Approval	DMT 03 ATEX E034
Technology	analogue
Keypad	Metal keypad with ice protection 21 keys with ABC lettering for name entries, 3 freely programmable memory keys enabling (emergency) telephone numbers to be dialled quickly

Noise suppression	> 3 dB thanks to integrated mouthpiece horn
Supply voltage	24 V DC-66 V DC
Supply current	0,015 A DC-0,10 A DC
Ringing alternating current	24 V AC-90 V AC (at 21-54 Hz ringing frequency) 30 V AC-90 V AC (at 16.6-54 Hz ringing frequency)
Tone ringing impedance	> 6.0 KΩ at 25 Hz and 24-90 V AC > 4.0 KΩ at 50 Hz and 24-90 V AC
Enquiry key	Flash function can be adjusted from 40 ms-399 ms
W conductor	Option to connect external call signalling sounder
Weight	5,8 kg
Mouthpiece	Electret microphone
Receiver	dynamic receiver with leakage field spool for inductively coupling hearing aids
Stabiliser bracket	integrated, adjustable stabiliser protection
Handset cord	steel-reinforced armoured cord made of V4A



dST-MB

ORDER DATA

Housing colour	Order number
black	410 050 000



AS1



VS1



EP1



HS1



mTCR



TH1



TH2

ACCESSORIES

Type	Type of accessory	Colour	Housing material	Weight	Order number		
AS1	Explosion-proof audible telephone call signalling sounder			500 g	410 100 004		
VS1	Explosion-proof visual-audible signalling sounder	black (RAL 9005)orange		1,42 kg	410 101 005		
		black (RAL 9005)red		1,42 kg	410 102 005		
		black (RAL 9005)clear		1,42 kg	410 104 005		
		black (RAL 9005)blue		1,42 kg	410 105 005		
		black (RAL 9005)green		1,42 kg	410 106 005		
EP1	Explosion-proof additional earpiece set			200 g	410 100 002		
HS1	Headset kit			1,33 kg	410 100 001		
mTCR	Explosion-proof telephone connecting relay			1,1 kg	410 100 100		
TH1	Telephone sound protection hood	yellow (RAL 1023)	PVC - plastic (UV and weather-resistant)	30 kg	410 100 012		
			glass-fibre-reinforced plastic (GFRP)	40 kg	410 100 008		
			Console (sheet steel, powder-coated)	17 kg	410 100 011		
			Metal	35 kg	410 100 006		
			red (RAL 3020)	PVC - plastic (UV and weather-resistant)	30 kg	410 100 014	
				glass-fibre-reinforced plastic (GFRP)	40 kg	410 100 015	
		Metal		35 kg	410 100 009		
		orange (RAL 2000)		PVC - plastic (UV and weather-resistant)	30 kg	410 100 013	
				glass-fibre-reinforced plastic (GFRP)	40 kg	410 100 007	
		Stainless steel		Stainless steel	40 kg	410 100 010	
		TH2	Telephone sound protection hood	yellow	Stainless steel	3,5 g	410 100 020
					PVC - plastic (UV and weather-resistant)	3,5 g	410 100 030



dFT3 Explosion-proof analogue telephone

- Explosion-proof analogue telephone
- Certified for gas and dust hazardous areas – zone 2, 22
- Degree of protection IP 65
- Impact-resistant polycarbonate housing
- For areas with temporary explosive atmospheres
- Available with armoured or spiral cord as an option
- Models with or without display
- Housing colours yellow, red, grey and black
- Can be used as a desk-mounted or wall-mounted telephone

II 3 G Ex nAnL IIC T5

II 3 D Ex tD A22 IP65 T80 °C

-20 °C ≤ Ta ≤ +55 °C

Zone 2, 22

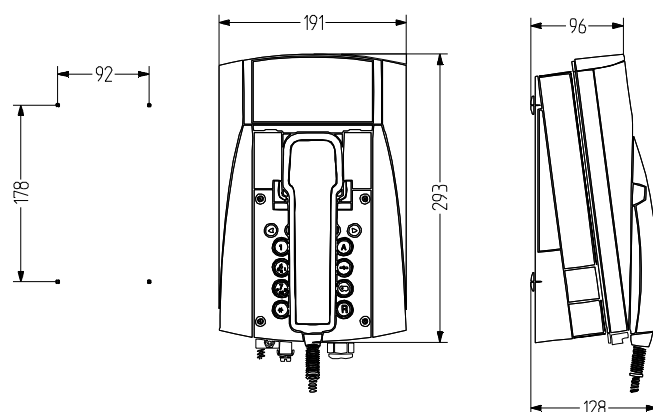

TECHNICAL DATA

Dialling method	MFV nach CCITTQ 23
Tone ringing volume	95 dB
Bell ringing frequency	programmable: 16–68 Hz
Pulse/pause ratio	programmable: 1.5:1 60/40 ms 2:1 66.7/33.3 ms
Flash time	~ 80 ms set as default 1 ms–999 ms can be programmed
Net access, acoustics	TBR 21, TBR 38
Incoming telephone line	TCP/La, TCP/Lb
Second bell	w1, w
Electrical safety	EN 60950
Transportation/storage temperature	-25 °C / +70 °C
Display temperature	-10 °C / +55 °C
Housing	Polycarbonate black, black/red, black/grey or black/yellow

Type of mounting	vertical wall mounting or Table mounting
Cable entry	1× M20 × 1.5 cable gland, 1× M20 × 1.5 blind plug, 2× M12 × 1.5 blind plugs
Connection technology	single wire or multiple wires up to 2.5 mm ²
Operating temperature	-20 °C / +55 °C
Degree of protection	IP65
Approval	BVS 09 ATEX E061
Technology	analogue
Supply voltage	24–66 V DC
Weight	2,3 kg
Display	available with and without
Mouthpiece	Electret microphone
Receiver	Dynamic receiver with magnetic field generator
Stabiliser bracket	as accessory



dFT3

ORDER DATA

Cord	Display	Housing colour	Order number
Coiled cord	with display	black/yellow	410 400 100
		black	410 400 000
		black/grey	410 400 300
		black/red	410 400 200
	without display	black/yellow	410 410 100
		black	410 410 000
		black/grey	410 410 300
		black/red	410 410 200
Armoured cord	with display	black/yellow	410 420 100
		black	410 420 000
		black/grey	410 420 300
		black/red	410 420 200
	without display	black/yellow	410 430 100
		black	410 430 000
		black/grey	410 430 300
		black/red	410 430 200



AS1



VS1



mTCR



TH1



TH2

ACCESSORIES

Type	Type of accessory	Colour	Housing material	Weight	Order number
AS1	Explosion-proof audible telephone call signalling sounder			500 g	410 100 004
VS1	Explosion-proof visual-audible signalling sounder	black (RAL 9005)orange		1,42 kg	410 101 005
		black (RAL 9005)red		1,42 kg	410 102 005
		black (RAL 9005)clear		1,42 kg	410 104 005
		black (RAL 9005)blue		1,42 kg	410 105 005
		black (RAL 9005)green		1,42 kg	410 106 005
mTCR	Explosion-proof telephone connecting relay			1,1 kg	410 100 100
TH1	Telephone sound protection hood	yellow (RAL 1023)	PVC - plastic (UV and weather-resistant)	30 kg	410 100 012
			glass-fibre-reinforced plastic (GFRP)	40 kg	410 100 008
			Console (sheet steel, powder-coated)	17 kg	410 100 011
			Metal	35 kg	410 100 006
		red (RAL 3020)	PVC - plastic (UV and weather-resistant)	30 kg	410 100 014
			glass-fibre-reinforced plastic (GFRP)	40 kg	410 100 015
			Metal	35 kg	410 100 009
			PVC - plastic (UV and weather-resistant)	30 kg	410 100 013
		orange (RAL 2000)	glass-fibre-reinforced plastic (GFRP)	40 kg	410 100 007
			PVC - plastic (UV and weather-resistant)	30 kg	410 100 013
			glass-fibre-reinforced plastic (GFRP)	40 kg	410 100 007
			Stainless steel	40 kg	410 100 010
TH2	Telephone sound protection hood	yellow	Stainless steel	3,5 g	410 100 020
			PVC - plastic (UV and weather-resistant)	3,5 g	410 100 030
STB	Stabiliser bracket				410 400 900

dST-IP Explosion-proof VoIP telephone

- Certified for gas and dust hazardous areas – zone 1, 2, 22
- Degree of protection IP 66 & impact resistance IK09
- Very robust weather-proof housing with steel-armoured handset cord to withstand high tensile forces
- For demanding industrial, onshore and offshore applications
- V4A steel keypad, designed for use with gloves
- Illuminated, pixel-based, heated display
- Intelligent and user-friendly menu structure
- Standard H.323, SIP, TSIP, SIPS protocols
- Power over Ethernet or external power supply

II 2G Rx e ib [ib] mb IIC T4 Gb

III 2D Ex ib [ib] tb IIIC T135 °

-40 °C ≤ Ta ≤ +60 °C/+40°C

Zone 1, 2, 22

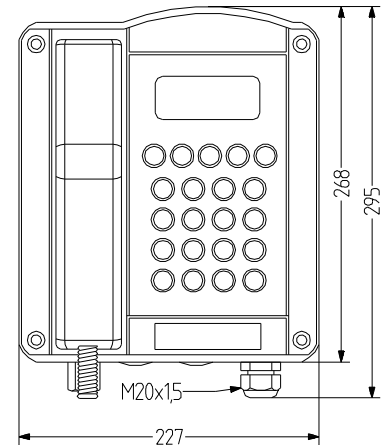
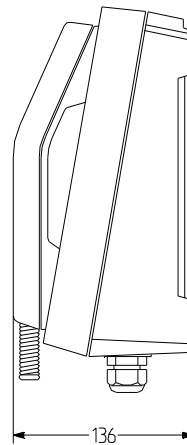

dST-IP

TECHNICAL DATA

Tone ringing volume	95 dB
External power supply voltage	19,2-52,8 V DC
Power requirement	12,95 W
Connection	port (10/100 Mbit/s)
Echo compensation	G.168
Housing	glass-fibre-reinforced polyester black
Type of mounting	vertical wall mounting
Operating temperature	-40 °C / +60 °C
Operating temperature	-40°C/+60°C
Degree of protection	IP66
Impact resistance	IK09
Current supply	Power over Ethernet as per IEEE 802.3af or external supply
Relay switching capacity	250 V AC - 5 A 100 Watt 30 V DC - 5 A 100 Watt 230 V DC- 0,5 A 100 Watt 50 V DC- 1 A 50 Watt
Technology	VOIP
Protocol	H.323, SIP, TSIP or SIPS
Weight	5 kg
Display	182 × 64 Pixel
Mouthpiece	Electret microphone
Receiver	Dynamic receiver with magnetic field generator
Stabiliser bracket	as standard
Handset cord	steel-reinforced armoured cord made of V4A
General	H.323 version 4 incl. H.225, H.235, H.245 and RAS gatekeeper routed signalling, H.450 Session Initiation Protocol (SIP), RTP, SRTP
RTCP	Real time control protocol - first level of 'quality of service'
RAS protocol	Support for external gatekeeper
DTMF	H.245 'alphanumeric' or 'single type'
VoIP features	H.245 fast connect en-bloc dialling overlapped sending
Encryption	Encrypted password authentication as per H.235
Quality of service	Prioritisation of IP packets over TOS and Diffserv, VLAN priority as per IEEE 802.1p/802.1p
Speech codes	G.711 A-law/μ-law (64 kbps), G.729A (16 kbps)

Access	using web browser with HTML Password-protected with secure authentication
Connections for trouble-shooting	Log and trace files, interface status indicators and ping connection test for internet protocol sending of SNMP traps
Update	Saving and reading of configuration, boot code and firmware update by means of HTML upload and automatic update using update server
DSL Zugang	PPPoE protocol
VPN	Tunnelling with PPTP encryption with MPPE
NAT	Network address translation - for translating official IP addresses into unofficial addresses and vice versa
DHCP	Dynamic host configuration protocol - IP interface settings
ICMP	Internet control message protocol - for ping tests
Ring tone generation	Automatic generation of ring tone as per European and US standards
Call switching	Call transfer, in all common variants: with/without enquiry, before/after answering, etc.
Call forwarding	Call diversion/redirection
Hold	Call hold/retrieve
Call waiting	Call waiting, with corresponding signal sent to calling subscriber
Message	Display on telephone indicating that there is a message
Pickup	Display on telephone indicating that a call can be taken
Pickup list	Display on telephone indicating which calls can be taken
Name Display	for signalling the name which is to be displayed
Callback	Call completion, with all common variants, such as callback when 'busy' and callback when 'not busy'
Conference	with 3 subscribers, including external subscribers
Telephone number identification	for separate signalling for telephone numbers or groups of telephone numbers
Multiple entries	maximum of 6 entries
Directory	automatic availability of all entries in central directory; integration of external databases via LDAP
Time	extremely accurate time information thanks to access to time server



dST-IP

ORDER DATA

Housing colour	Order number
black	410 030 000



VS1



HS1



TH1



TH2

ACCESSORIES

Type	Type of accessory	Colour	Housing material	Weight	Order number		
VS1	Explosion-proof visual-audible signalling sounder	black (RAL 9005)orange		1,42 kg	410 101 005		
		black (RAL 9005)red		1,42 kg	410 102 005		
		black (RAL 9005)clear		1,42 kg	410 104 005		
		black (RAL 9005)blue		1,42 kg	410 105 005		
		black (RAL 9005)green		1,42 kg	410 106 005		
HS1	Headset kit			1,33 kg	410 100 001		
TH1	Telephone sound protection hood	yellow (RAL 1023)	PVC – plastic (UV and weather-resistant)	30 kg	410 100 012		
			glass-fibre-reinforced plastic (GFRP)	40 kg	410 100 008		
			Console (sheet steel, powder-coated)	17 kg	410 100 011		
			Metal	35 kg	410 100 006		
		red (RAL 3020)	PVC – plastic (UV and weather-resistant)	30 kg	410 100 014		
			glass-fibre-reinforced plastic (GFRP)	40 kg	410 100 015		
			Metal	35 kg	410 100 009		
		orange (RAL 2000)	PVC – plastic (UV and weather-resistant)	30 kg	410 100 013		
			glass-fibre-reinforced plastic (GFRP)	40 kg	410 100 007		
			Stainless steel	40 kg	410 100 010		
		TH2	Telephone sound protection hood	Stainless steel		3,5 g	410 100 020
				yellow	PVC – plastic (UV and weather-resistant)	3,5 g	410 100 030



dFT3-IP Explosion-proof VoIP telephone

- Certified for gas and dust hazardous areas – zone 2, 22
- Degree of protection IP 65
- Impact-resistant polycarbonate housing
- Housing colours yellow, red, grey and black
- Intelligent and user-friendly menu structure
- Standard H.323, SIP, TSIP, SIPS protocols
- Power over Ethernet power supply
- Available with armoured or spiral cord as an option
- Illuminated keypad/pixel-based LCD display
- Can be used as a desk-mounted or wall-mounted telephone

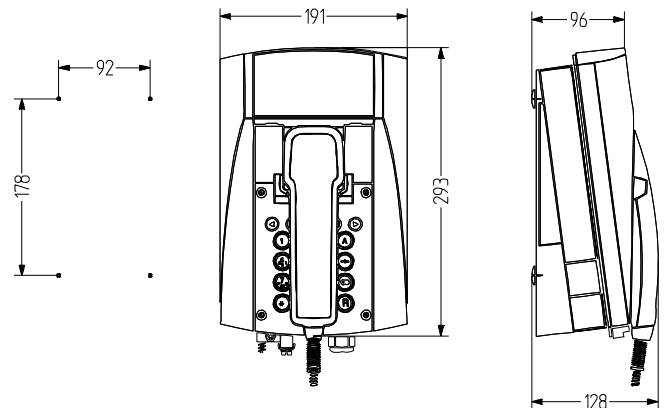

II 3G Ex nA nL II C T5

II 3D Ex tD A22 IP65 T80°C

-20°C bis +55°C

Zone 2, 22



dFT3-IP

TECHNICAL DATA

Tone ringing volume	95 dB
Connection	10/100 BASE-T Ethernet LAN
Echo compensation	G.168
Housing	Polycarbonate black, black/red, black/grey or black/yellow
Connection technology	to a single 10/100 BASE-T Ethernet LAN, RJ45
Operating temperature	-20 °C / +55 °C
Degree of protection	IP65
Current supply	Power over Ethernet as per IEEE 802.3af
Technology	VOIP
Keypad	illuminated keypad
Protocol	H.323, SIP, TSIP or SIPS
Weight	2,4 kg
Display	128 × 64 Pixel
General	H.323 version 4 incl. H.225, H.235, H.245 and RAS gatekeeper routed signalling, H.450 Session Initiation Protocol (SIP), RTP, SRTP
RTCP	Real time control protocol - first level of 'quality of service'
RAS protocol	Support for external gatekeeper
DTMF	H.245 'alphanumeric' or 'single type'
VoIP features	H.245 fast connect en-bloc dialling overlapped sending
Encryption	Encrypted password authentication as per H.235
Quality of service	Prioritisation of IP packets over TOS and Diffserv, VLAN priority as per IEEE 802.1p/802.1p
Speech codes	G.711 A-law/ μ -law (64 kbps), G.723.1 (5,3 kbps), G.729A (16 kbps)
Access	using web browser with HTML Password-protected with secure authentication

Connections for trouble-shooting	Log and trace files, interface status indicators and ping connection test for internet protocol sending of SNMP traps
Update	Saving and reading of configuration, boot code and firmware update by means of HTML upload and automatic update using update server
DSL Zugang	PPPoE protocol
VPN	Tunnelling with PPTP encryption with MPPE
NAT	Network address translation - for translating official IP addresses into unofficial addresses and vice versa
DHCP	Dynamic host configuration protocol - IP interface settings
ICMP	Internet control message protocol - for ping tests
Ring tone generation	Automatic generation of ring tone as per European and US standards
Call switching	Call transfer, in all common variants: with/without enquiry, before/after answering, etc.
Call forwarding	Call diversion/redirection
Hold	Call hold/retrieve
Call waiting	Call waiting, including signalling of second call information
Message	Display on telephone indicating that there is a message
Name Display	for signalling the name which is to be displayed
Conference	with 3 subscribers, including external subscribers
Telephone number identification	displays calling numbers
Multiple entries	maximum of 6 entries
Directory	local, integration or external database
Time	extremely accurate time information thanks to access to time server



dFT3-IP

ORDER DATA

Cord	Housing colour	Order number
Coiled cord	black/red	410 450 200
	black	410 450 000
	black/grey	410 450 300
	black/yellow	410 450 100
Armoured cord	black/red	410 460 200
	black	410 460 000
	black/grey	410 460 300
	black/yellow	410 460 100



TH1



TH2

ACCESSORIES

Type	Type of accessory	Colour	Housing material	Weight	Order number		
TH1	Telephone sound protection hood	yellow (RAL 1023)	PVC - plastic (UV and weather-resistant)	30 kg	410 100 012		
			glass-fibre-reinforced plastic (GFRP)	40 kg	410 100 008		
			Console (sheet steel, powder-coated)	17 kg	410 100 011		
			Metal	35 kg	410 100 006		
		orange (RAL 2000)	PVC - plastic (UV and weather-resistant)	30 kg	410 100 013		
			glass-fibre-reinforced plastic (GFRP)	40 kg	410 100 007		
		red (RAL 3020)	PVC - plastic (UV and weather-resistant)	30 kg	410 100 014		
			glass-fibre-reinforced plastic (GFRP)	40 kg	410 100 015		
			Metal	35 kg	410 100 009		
			Stainless steel	40 kg	410 100 010		
		TH2	Telephone sound protection hood	yellow	PVC - plastic (UV and weather-resistant)	3,5 g	410 100 030
					Stainless steel	3,5 g	410 100 020
STB	Stabiliser bracket				410 400 900		



AS1 Explosion-proof audible telephone call signalling sounder

- Several tones/intermittent tone frequencies can be selected
- Die-cast aluminium housing
- High degree of protection IP 66
- Certified for zone 1 and 2
- Power supply via telephone call voltage
- Works independently even during power failures
- For use in explosive gas atmospheres in loud ambient conditions, to make an incoming telephone call more noticeable

II 2 G Ex e ib mb IIC T6
Zone 1, 2



TECHNICAL DATA

audible signal transmitter	Loudspeaker
Tone ringing volume	90 dB
Input impedance	bei 25 HZ $Z \geq 8 \Omega$ bei 50 HZ $Z \geq 4 \Omega$
Superimposed supply voltage	0 V DC - 63 V DC
Tone sequence frequency	5 to 20 Hz in 4 settings, can be adjusted with DIP switch
Equipotential bonding	Connection inside housing
Current	≤ 3 A
Housing	Die-cast aluminium, polycarbonate upper part black (RAL 9005)
Type of mounting	Wall mounting or Ceiling mounting
Cable entry	1 x M20x1,5; 1 x M12x1,5
Connection technology	0.75-1.5 mm ² /AWG 14, single or fine wire
Tone	Wobble tone, One tone, Two tones or Three tones Can be adjusted with DIP switch
Operating temperature	-20 °C / +40 °C
Degree of protection	IP66
Approval	BVS 03 ATEX E430
Ringing alternating current	32 V AC - 75 V AC
Insulation class	I
Weight	500 g

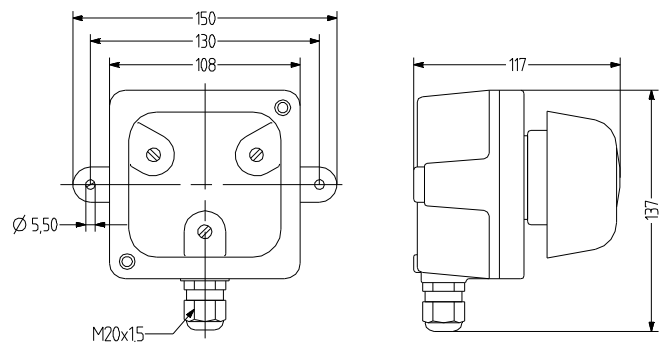

AS1

ORDER DATA

Type	Volume	Order number
AS1	90 db	410 100 004



VS1 Explosion-proof visual-audible signalling sounder

- For universal industrial use
- Certified for gas hazardous areas of zone 1 and 2
- Several tones/intermittent tone frequencies can be selected
- 2× 1 J strobe energy

- Die-cast aluminium housing
- 5 lens colours
- Degree of protection IP 66
- Encapsulation "m"
- Terminal connection chamber "increased safety e"
- 230 V AC power supply

II 2 G Ex e mb [ib] IIC T6/T5/T4 Gb
 -20 °C ≤ Ta ≤ +40 °C/+50 °C/+60 °C
 Zone 1, 2



TECHNICAL DATA

audible signal transmitter	Loudspeaker
visual signal transmitter	2 flashtubes with 1 J
Tone ringing volume	90 dB
Mains connection	230 V AC -15% +10%, 50/60 Hz
Type of ignition protection	≤ 60 min at Ta +60°C ≤ 15 min at 60 Hz (30 min pause)
Telephone connection	30 V AC - 75 V AC 23-54 Hz 0-63 V DC
Housing	Die-cast aluminium black (RAL 9005)
Lens	Polycarbonate, orange, red, clear, blue or green
Type of mounting	Wall mounting or Ceiling mounting
Cable entry	2× cable glands M20 × 1.5 6-12 mm (main circuit) 5-10 mm (telephone circuit)
Connection technology	up to 1.5 mm² single or fine wire
Strobe/flash frequency	1-2 Hz
Tone	3 Tones, One tone, Two tones or Three tones Can be adjusted with DIP switch
Duty cycle	≤ 60 min at Ta +60°C; ≤ 15 min at 60 Hz (30 min pause)
Operating temperature	-20 °C / +60 °C
Degree of protection	IP66
Approval	PTB 04 ATEX 2012
Weight	1,42 kg

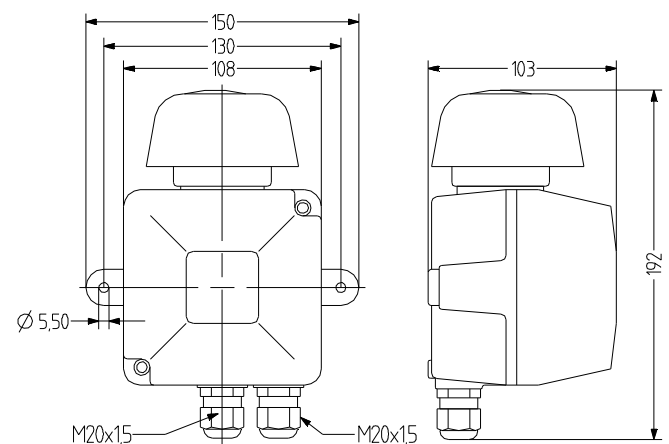

VS1

ORDER DATA

Lens colour	Order number
orange	410 101 005
red	410 102 005
clear	410 104 005
blue	410 105 005
green	410 106 005



EP1 Explosion-proof additional earpiece set

- Explosion-proof, intrinsically safe additional earpiece
- Enables other people to follow a telephone conversation
- Reduction of loud ambient noise during a telephone conversation
- Degree of protection IP 54
- Certified for zone 1 and 2
- Set contents: Additional earpiece with dynamic receiver, Spiral cord and cable gland, Bracket for attaching to the telephone
- For use in explosive gas atmospheres

II 2 G Ex ia IIC T6 Gb

II 2 D Ex ia IIIB T80 °C Db

-25 °C ≤ Ta ≤ +60 °C

Zone 1, 2



TECHNICAL DATA

Connection cord	Coiled cord, 2 wires
Housing	Polyurethane elastomer blue
Cable entry	M20 × 1.5 cable gland
Operating temperature	-25 °C / +60 °C
Degree of protection	IP54
Approval	BVS 03 ATEX E429
Weight	200 g
Receiver	dynamic receiver

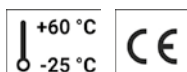
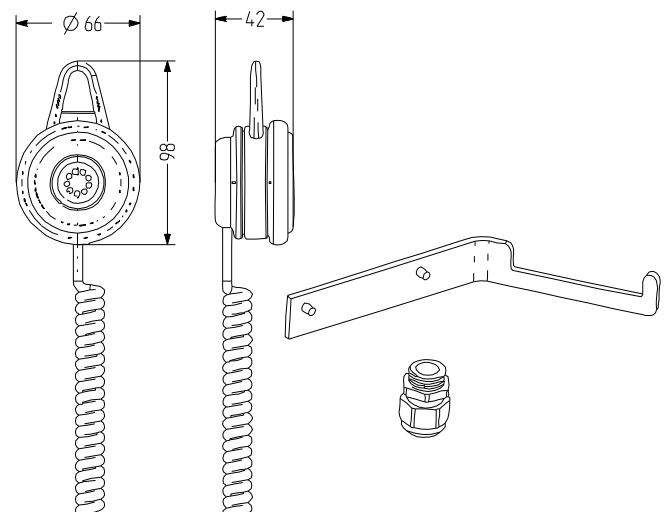

EP1

ORDER DATA

Description	Order number
Explosion-proof additional earpiece set	410 100 002



HS1 Headset kit

- Explosion-proof, intrinsically safe headset
- Reduction of loud ambient noise during a telephone conversation
- Facilitates communication during activities where both hands need to be free
- Certified for zone 1 and 2
- For use in explosive gas atmospheres
- Set contents: Headset with dynamic receiver, 14 m connecting cord, Bracket for attaching to the telephone

II 2G Ex ib IIB T4 Gb
Zone 1, 2



TECHNICAL DATA

Connection cord	14 m connecting cord
Housing	other
Cable entry	M20 × 1.5 cable gland
Operating temperature	-20 °C / +60 °C
Degree of protection	IP66
Weight	1,33 kg
Mouthpiece	noise-compensating close-range electret microphone
Receiver	dynamic receiver

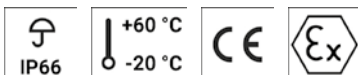

HS1

ORDER DATA

Description	Order number
Headset kit	410 100 001



mTCR Explosion-proof telephone connecting relay

- Explosion-proof telephone connecting relay
- Potential-free contacts for individual connection of up to 2 visual or audible signalling devices
- Call break bypass can be individually adjusted
- High degree of protection IP 66
- Housing made of electrostatically conductive glass-fibre-reinforced polyester

II 2 G Ex e ib mb IIC T4 Gb

II 2 D Ex tb IIIC T135 °C Db

-40 °C ≤ T_a ≤ +70 °C



TECHNICAL DATA

Connection	Call voltage of analogue telephone network, AC 30 V-100 V (TNV-3)
Input impedance	≥ 8.0 KΩ at 20-68 Hz and 30-100 V A
Housing	glass-fibre-reinforced polyester black
Type of mounting	any
Operating temperature	-40 °C / +70 °C
Degree of protection	IP66
Weight	1,1 kg

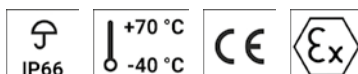
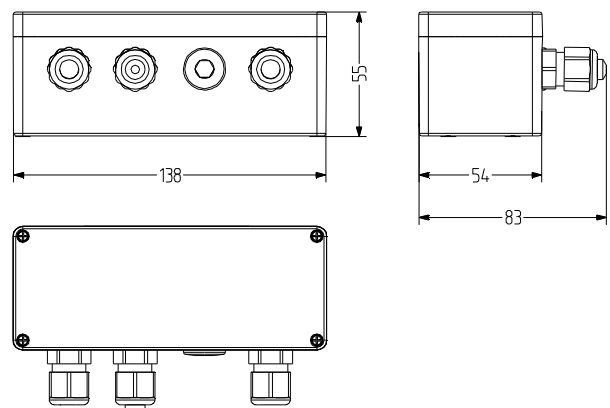

mTCR

ORDER DATA

Description	Order number
Explosion-proof telephone connecting relay	410 100 100



wST weather-proof analogue telephone

- Resistant to temperature differences, humidity, seawater, acids, alkalis, greases, etc.
- High degree of protection IP 66 & impact resistance IK09
- Steel-armoured handset cord to withstand high tensile forces
- Robust, impact-resistant housing
- For demanding industrial, onshore and offshore applications
- V4A steel keypad, designed for use with gloves
- Easily readable alphanumerical display
- Freely programmable, housing colours black and red
- Version without keypad/display available as emergency telephone

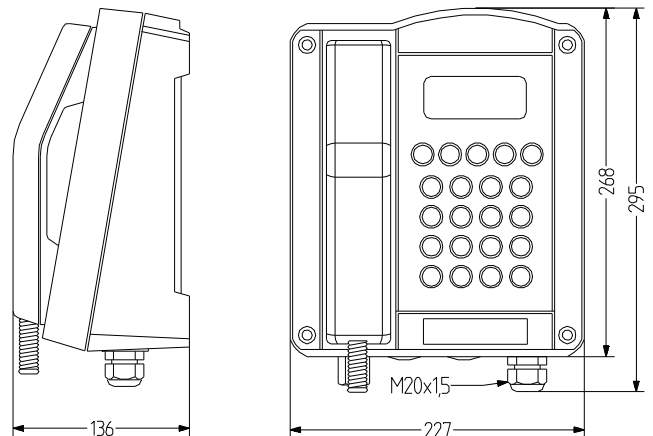

TECHNICAL DATA

Dialling method	PD DTMF operation can be selected from menu DTMF operation as per CCITT recommendation Q.23 PD operation with pulse/pause ratio of 1.5:1 or 2:1, which can be selected via menu navigation
Tone ringing volume	90 dB
Transportation/storage temperature	-25°C/+70°C
Housing	Glass-fibre-reinforced polyester red or black
Cable entry	1× M20 × 1.5, 2× M20 × 1.5 blind plugs
Connection technology	up to 4 mm ² rigid, up to 2.5 mm ² flexible
Operating temperature	-25 °C / +60 °C
Degree of protection	IP66
Impact resistance	IK09
Technology	analogue
Keypad	Metal keypad with ice protection 21 keys with ABC lettering for name entries
Noise suppression	> 3 dB thanks to integrated mouthpiece horn

Supply voltage	24 V DC - 66 V DC
Supply current	0,015 A DC-0,100 A DC
Ringing alternating current	24 V AC-90 V AC (at 21-54 Hz ringing frequency) 30 V AC-90 V AC (at 16.6-54 Hz ringing frequency)
Tone ringing impedance	> 6.0 KΩ at 25 Hz and 24-90 V AC > 4.0 KΩ at 50 Hz and 24-90 V AC
Enquiry key	Flash function can be adjusted from 40 ms-399 ms
W conductor	Option to connect external call signalling sounder
Weight	5,4 kg
Display	2-line alphanumerical display with pictograms, visible area 78 × 26 mm
Mouthpiece	Electret microphone
Receiver	dynamic receiver with leakage field spool for inductively coupling hearing aids
Stabiliser bracket	integrated, adjustable stabiliser protection
Handset cord	steel-reinforced armoured cord made of V4A



wST

ORDER DATA

Type	Keypad	Display	Housing colour	
			black	red
WST1	with keypad	with display	410 110 000	410 110 100
WST2	without keypad	without display	410 120 000	410 120 100



VS2



LS2



EP2



HS2



TCR



TH1



TH2

ACCESSORIES

Type	Type of accessory	Colour	Housing material	Weight	Order number	
VS2	Visual-audible telephone call signalling sounder	black (RAL 9005)orange		935 g	410 201 005	
		black (RAL 9005)red		935 g	410 202 005	
		black (RAL 9005)clear		935 g	410 204 005	
		black (RAL 9005)blue		935 g	410 205 005	
		black (RAL 9005)green		935 g	410 206 005	
LS2	Loudspeaker set			1,1 kg	410 200 003	
EP2	Additional earpiece set			200 g	410 200 002	
HS2	Headset kit			410 g	410 200 001	
TCR	Weather-proof telephone switch relay			750 g	410 100 200	
TH1	Telephone sound protection hood	yellow (RAL 1023)	PVC - plastic (UV and weather-resistant)	30 kg	410 100 012	
			glass-fibre-reinforced plastic (GFRP)	40 kg	410 100 008	
			Console (sheet steel, powder-coated)	17 kg	410 100 011	
			Metal	35 kg	410 100 006	
		red (RAL 3020)	PVC - plastic (UV and weather-resistant)	30 kg	410 100 014	
			glass-fibre-reinforced plastic (GFRP)	40 kg	410 100 015	
			Metal	35 kg	410 100 009	
		orange (RAL 2000)	PVC - plastic (UV and weather-resistant)	30 kg	410 100 013	
			glass-fibre-reinforced plastic (GFRP)	40 kg	410 100 007	
		Stainless steel	Stainless steel	40 kg	410 100 010	
		TH2	Telephone sound protection hood	Stainless steel	3,5 g	410 100 020
				yellow	PVC - plastic (UV and weather-resistant)	3,5 g



wST-MB weather-proof analogue telephone

- Resistant to temperature differences, humidity, seawater, acids, alkalis, greases, etc.
- High degree of protection IP 66 & impact resistance IK09
- Steel-armoured handset cord to withstand high tensile forces
- Robust, impact-resistant housing
- For demanding industrial, onshore and offshore applications
- V4A steel keypad, designed for use with gloves
- 3 freely programmable memory buttons for quick dialling
- Freely programmable, housing colour black
- Convenient telephone functions

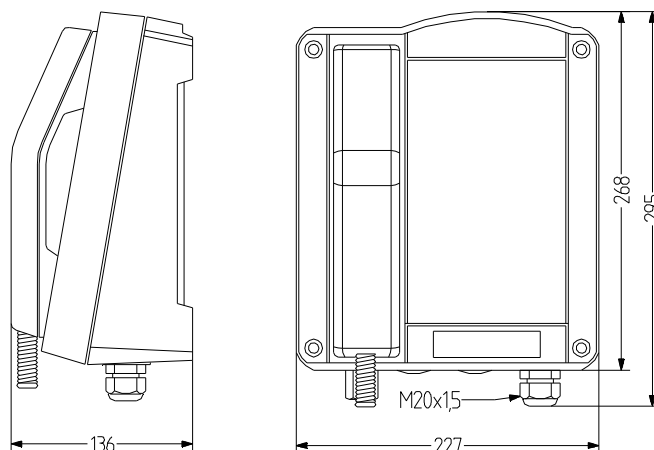

TECHNICAL DATA

Dialling method	PD DTMF operation can be selected from menu DTMF operation as per CCITT recommendation Q.23 PD operation with pulse/pause ratio of 1.5:1 or 2:1, which can be selected via menu navigation
Tone ringing volume	90 dB
Transportation/storage temperature	-25 °C / +70 °C
Housing	glass-fibre-reinforced polyester black
Cable entry	1× M20 × 1.5, 2× blind plugs M20 × 1.5
Connection technology	up to 4 mm ² rigid, up to 2.5 mm ² flexible
Operating temperature	-25 °C / +60 °C
Degree of protection	IP66
Impact resistance	IK09
Technology	analogue
Keypad	Metal keypad with ice protection 21 keys with ABC lettering for name entries, 3 freely programmable memory keys enabling (emergency) telephone numbers to be dialled quickly

Noise suppression	> 3 dB thanks to integrated mouthpiece horn
Supply voltage	24 V DC - 66 V DC
Supply current	0,015 A DC-0,100 A DC
Ringing alternating current	24 V AC-90 V AC (at 21-90 Hz ringing frequency) 30 V AC-90 V AC (at 16.6-90 Hz ringing frequency)
Tone ringing impedance	> 6.0 KΩ at 25 Hz and 24-90 V AC > 4.0 KΩ at 50 Hz and 24-90 V AC
Enquiry key	Flash function can be adjusted from 40 ms-399 ms
W conductor	Option to connect external call signalling sounder
Weight	5,5 kg
Mouthpiece	Electret microphone
Receiver	dynamic receiver with leakage field spool for inductively coupling hearing aids
Stabiliser bracket	integrated, adjustable stabiliser protection
Handset cord	steel-reinforced armoured cord made of V4A



wST-MB

ORDER DATA

Housing colour	Order number
black	410 150 100



VS2



LS2



EP2



HS2



TCR



TH1



TH2

ACCESSORIES

Type	Type of accessory	Colour	Housing material	Weight	Order number	
VS2	Visual-audible telephone call signalling sounder	black (RAL 9005)orange		935 g	410 201 005	
		black (RAL 9005)red		935 g	410 202 005	
		black (RAL 9005)clear		935 g	410 204 005	
		black (RAL 9005)blue		935 g	410 205 005	
		black (RAL 9005)green		935 g	410 206 005	
LS2	Loudspeaker set			1,1 kg	410 200 003	
EP2	Additional earpiece set			200 g	410 200 002	
HS2	Headset kit			410 g	410 200 001	
TCR	Weather-proof telephone switch relay			750 g	410 100 200	
TH1	Telephone sound protection hood	yellow (RAL 1023)	PVC – plastic (UV and weather-resistant)	30 kg	410 100 012	
			glass-fibre-reinforced plastic (GFRP)	40 kg	410 100 008	
			Console (sheet steel, powder-coated)	17 kg	410 100 011	
			Metal	35 kg	410 100 006	
		red (RAL 3020)	PVC – plastic (UV and weather-resistant)	30 kg	410 100 014	
			glass-fibre-reinforced plastic (GFRP)	40 kg	410 100 015	
			Metal	35 kg	410 100 009	
		orange (RAL 2000)	PVC – plastic (UV and weather-resistant)	30 kg	410 100 013	
			glass-fibre-reinforced plastic (GFRP)	40 kg	410 100 007	
		Stainless steel	Stainless steel	40 kg	410 100 010	
		TH2	Telephone sound protection hood	Stainless steel	3,5 g	410 100 020
				yellow	PVC – plastic (UV and weather-resistant)	3,5 g



wFT3 weather-proof analogue telephone

- For universal applications, resistant to high humidity, maritime climates, etc.
- High degree of protection IP 65
- Impact-resistant polycarbonate housing
- Housing colours yellow, red, grey and black
- Available with armoured or spiral cord as an option
- Models with or without display/keypad
- Receiver can be fixed with stabiliser bracket
- Can be used as a desk-mounted or wall-mounted telephone
- Receiver can be securely fixed with stabiliser bracket
- Comprehensive range of accessories

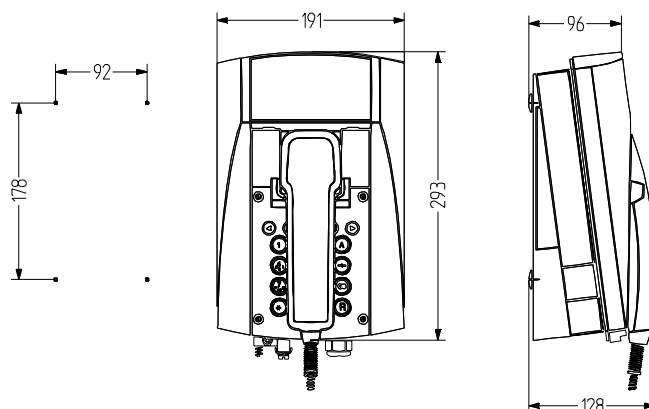

TECHNICAL DATA

Dialling method	DTMF as per ITU-T Q.23 Tone duration unlimited or 90 ms PD pulse/pause ratio 1.5:1 (60/40 ms) or 2:1 (66.7/33.3 ms)
Tone ringing volume	95 dB
Ringing frequency	programmable: 16–68 Hz
Incoming telephone line	TCP/La, TCP/Lb
Second bell	w1, w
Housing	Polycarbonate black, black/red, black/grey or black/yellow
Type of mounting	vertical wall mounting or Table mounting
Cable entry	1× M20 × 1.5 cable gland, 1× M20 × 1.5 blind plug, 2× M12 × 1.5 blind plugs
Connection technology	single wire or multiple wires up to 2.5 mm ²
Operating temperature	-25 °C / +55 °C

Operating temperature	-25°C to 55°C (display: 12:12 -10°C to +50 °C)
Degree of protection	IP65
Technology	analogue
Supply voltage	24 - 66 DC
Supply current	0,019 - 0,10 A
Ringing alternating current	30 - 90 V AC
Weight	2,295 kg
Display	2-line alphanumerical display with pictograms, visible area 78 × 26 mm
Mouthpiece	Electret microphone
Receiver	dynamic receiver with magnetic field generator
Stabiliser bracket	optional
Handset cord	Spiral cord

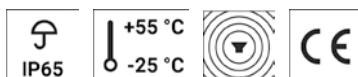

wFT3

ORDER DATA

Cord	Keypad	Display	Housing colour	Order number	
Coiled cord	with keypad	without display	black/red	410 310 200	
			black/yellow	410 310 100	
			black	410 310 000	
			black/grey	410 310 300	
		with display	black/red	410 300 200	
			black/yellow	410 300 100	
	Armoured cord	with keypad	without display	black/red	410 330 200
				black/yellow	410 330 100
				black	410 330 000
				black/grey	410 330 300
			with display	black/red	410 320 200
				black/yellow	410 320 100
without keypad		without display	black	410 300 000	
			black/grey	410 300 300	
			black/red	410 340 200	
			black/yellow	410 340 100	
			black	410 340 000	
			black/grey	410 340 300	



VS2



TCR



TH1



TH2

ACCESSORIES

Type	Type of accessory	Colour	Housing material	Weight	Order number
VS2	Visual-audible telephone call signalling sounder	black (RAL 9005)orange		935 g	410 201 005
		black (RAL 9005)red		935 g	410 202 005
		black (RAL 9005)clear		935 g	410 204 005
		black (RAL 9005)blue		935 g	410 205 005
		black (RAL 9005)green		935 g	410 206 005
TCR	Weather-proof telephone switch relay			750 g	410 100 200
TH1	Telephone sound protection hood	yellow (RAL 1023)	PVC - plastic (UV and weather-resistant)	30 kg	410 100 012
			glass-fibre-reinforced plastic (GFRP)	40 kg	410 100 008
			Console (sheet steel, powder-coated)	17 kg	410 100 011
			Metal	35 kg	410 100 006
		red (RAL 3020)	PVC - plastic (UV and weather-resistant)	30 kg	410 100 014
			glass-fibre-reinforced plastic (GFRP)	40 kg	410 100 015
			Metal	35 kg	410 100 009
		orange (RAL 2000)	PVC - plastic (UV and weather-resistant)	30 kg	410 100 013
			glass-fibre-reinforced plastic (GFRP)	40 kg	410 100 007
			Stainless steel	40 kg	410 100 010
TH2	Telephone sound protection hood	Stainless steel	3,5 g	410 100 020	
		yellow	PVC - plastic (UV and weather-resistant)	3,5 g	410 100 030
STB	Stabiliser bracket				410 400 900



wIND weather-proof analogue telephone

- Weather-proof analogue telephone for outdoor and indoor use
- For universal applications, resistant to high humidity, maritime climates, etc.
- High degree of protection IP 66 (closed) IP 65 (open)
- Impact-resistant polycarbonate housing
- Yellow or transparent protective door
- Eye-catching yellow housing colour – easy to spot
- Models with or without keypad
- Model with visual LED call indicator
- For wall mounting
- Comprehensive range of accessories

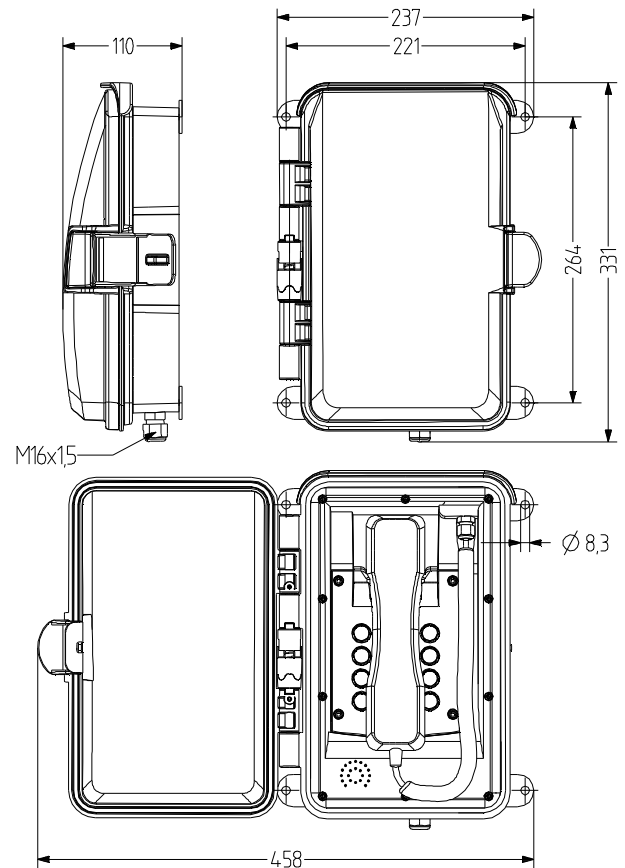

TECHNICAL DATA

Dialling method	DTMF as per ITU-T Q.23 Tone duration unlimited or 90 ms PD pulse/pause ratio 1.5:1 (60/40 ms) or 2:1 (66.7/33.3 ms)
Tone ringing volume	90 dB when protective door open, 65 dB when protective door closed
Incoming telephone line	TCP/La, TCP/Lb
Second bell	w1, w
Transportation/storage temperature	-25°C/+70°C
Housing	Polycarbonate yellow
Type of mounting	vertical wall mounting
Cable entry	2× cable glands M16 × 1.5 for cable diameter of 5–9 mm
Connection technology	single wire or multiple wires up to 2.5 mm ²
Operating temperature	-25 °C / +55 °C

Operating temperature	-25°C bis 55°C
Degree of protection	IP66 (when protective door closed)
Technology	analogue
Supply voltage	24 - 66 V DC
Supply current	0,019 - 0,10 A
Ringing alternating current	30–90 V AC at 16–68 Hz ringing frequency
Tone ringing impedance	≥ 6.0 kΩ at 25 Hz, ≥ 3.5 kΩ at 50 Hz
Enquiry key	only for DTMF 80 ms, 120 ms, 600 ms
Weight	2,3 kg (incl. telephone bracket)
Display	without
Mouthpiece	Electret microphone
Receiver	dynamic receiver
Handset cord	Spiral cord

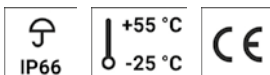

wIND

ORDER DATA

Keypad	Protective doors	Housing colour	Order number
with keypad	yellow	yellow	410 700 100
	transparent	yellow	410 700 110
	transparent, with visual call display	yellow	410 700 200
without keypad	yellow	yellow	410 710 100
	transparent	yellow	410 710 110



VS2



TH1



TH2

ACCESSORIES

Type	Type of accessory	Colour	Housing material	Weight	Order number		
VS2	Visual-audible telephone call signalling sounder	black (RAL 9005)orange		935 g	410 201 005		
		black (RAL 9005)red		935 g	410 202 005		
		black (RAL 9005)clear		935 g	410 204 005		
		black (RAL 9005)blue		935 g	410 205 005		
		black (RAL 9005)green		935 g	410 206 005		
TH1	Telephone sound protection hood	yellow (RAL 1023)	PVC – plastic (UV and weather-resistant)	30 kg	410 100 012		
			glass-fibre-reinforced plastic (GFRP)	40 kg	410 100 008		
			Console (sheet steel, powder-coated)	17 kg	410 100 011		
			Metal	35 kg	410 100 006		
		red (RAL 3020)	PVC – plastic (UV and weather-resistant)	30 kg	410 100 014		
			glass-fibre-reinforced plastic (GFRP)	40 kg	410 100 015		
			Metal	35 kg	410 100 009		
		orange (RAL 2000)	PVC – plastic (UV and weather-resistant)	30 kg	410 100 013		
			glass-fibre-reinforced plastic (GFRP)	40 kg	410 100 007		
		Stainless steel	Stainless steel	40 kg	410 100 010		
		TH2	Telephone sound protection hood	yellow	PVC – plastic (UV and weather-resistant)	3,5 g	410 100 030
					Stainless steel	3,5 g	410 100 020



wST-IP weather-proof VoIP telephone

- Resistant to temperature differences, humidity, seawater, acids, alkalis, greases, etc.
- High degree of protection IP 66 & impact resistance IK09
- Steel-armoured handset cord to withstand high tensile forces
- Robust, impact-resistant housing
- For demanding industrial, onshore and offshore applications
- V4A steel keypad, designed for use with gloves
- Illuminated, pixel-based, heated display
- Intelligent and user-friendly menu structure
- Standard H.323, SIP, TSIP, SIPS protocols
- Power over Ethernet or external power supply

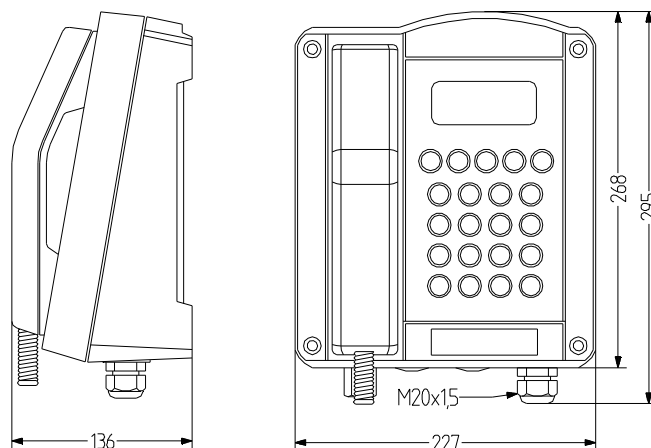

wST-IP

TECHNICAL DATA

Tone ringing volume	98 dB
External power supply voltage	15–57 V DC when the optional, electrically isolated inputs are not used 21.5–57 V DC when the optional, electrically isolated inputs are used
Power requirement	13 W
Connection	RJ45 port (10/100 Mbit/s)
Echo compensation	G.168
Housing	glass-fibre-reinforced polyester red or black
Type of mounting	vertical wall mounting
Operating temperature	-40 °C / +70 °C
Degree of protection	IP66
Impact resistance	IK09
Current supply	Power over Ethernet as per IEEE 802.3af or external supply
Relay switching capacity	240 V AC - 6 A 24 V DC - 6 A 32 V DC - 5 A 48 V DC - 1 A
Technology	VOIP
Protocol	H.323, SIP, TSIP or SIPS
Weight	5 kg
Display	182 × 64 Pixel
Mouthpiece	Electret microphone
Receiver	Dynamic receiver with magnetic field generator
Stabiliser bracket	as standard
General	H.323 version 4 incl. H.225, H.235, H.245 and RAS gatekeeper routed signalling, H.450 Session Initiation Protocol (SIP), RTP, SRTP
RTCP	Real time control protocol - first level of 'quality of service'
DTMF	H.245 'alphanumeric' or 'single type'
VoIP features	H.245 fast connect en-bloc dialling overlapped sending
Encryption	Encrypted password authentication as per H.235
Quality of service	Prioritisation of IP packets over TOS and Diffserv, VLAN priority as per IEEE 802.1p/802.1p
Speech codes	G.711 A-law/μ-law (64 kbps), G.729A (16 kbps)

Access	using web browser with HTML Password-protected with secure authentication
Connections for trouble-shooting	Log and trace files, interface status indicators and ping connection test for internet protocol sending of SNMP traps
Update	Saving and reading of configuration, boot code and firmware update by means of HTML upload and automatic update using update server
DSL Zugang	PPPoE protocol
VPN	Tunnelling with PPTP encryption with MPPE
NAT	Network address translation - for translating official IP addresses into unofficial addresses and vice versa
DHCP	Dynamic host configuration protocol - IP interface settings
ICMP	Internet control message protocol - for ping tests
Ring tone generation	Automatic generation of ring tone as per European and US standards
Call switching	Call transfer, in all common variants: with/without enquiry, before/after answering, etc.
Call forwarding	Call diversion/redirection
Hold	Call hold/retrieve
Call waiting	Call waiting, with corresponding signal sent to calling subscriber
Message	Display on telephone indicating that there is a message
Pickup	Display on telephone indicating that a call can be taken
Pickup list	Display on telephone indicating which calls can be taken
Name Display	for signalling the name which is to be displayed
Callback	Call completion, with all common variants, such as call-back when 'busy' and callback when 'not busy'
Conference	with 3 subscribers, including external subscribers
Telephone number identification	for separate signalling for telephone numbers or groups of telephone numbers
Multiple entries	maximum of 6 entries
Directory	automatic availability of all entries in central directory; integration of external databases via LDAP
Time	extremely accurate time information thanks to access to time server



wST-IP

ORDER DATA

Cord	Relay contact	Switch LAN module	Housing colour	
			black	red
Armoured cord	without relay contact	with switch LAN module	410 130 100	410 130 110
		without switch LAN module	410 130 000	410 130 010
	with relay contact	with switch LAN module	410 130 300	410 130 310
		without switch LAN module	410 130 200	410 130 210



VS2



HS2



TH1



TH2

ACCESSORIES

Type	Type of accessory	Colour	Housing material	Weight	Order number	
VS2	Visual-audible telephone call signalling sounder	black (RAL 9005)orange		935 g	410 201 005	
		black (RAL 9005)red		935 g	410 202 005	
		black (RAL 9005)clear		935 g	410 204 005	
		black (RAL 9005)blue		935 g	410 205 005	
		black (RAL 9005)green		935 g	410 206 005	
HS2	Headset kit			410 g	410 200 001	
TH1	Telephone sound protection hood	yellow (RAL 1023)	PVC - plastic (UV and weather-resistant)	30 kg	410 100 012	
			glass-fibre-reinforced plastic (GFRP)	40 kg	410 100 008	
			Console (sheet steel, powder-coated)	17 kg	410 100 011	
			Metal	35 kg	410 100 006	
		red (RAL 3020)	PVC - plastic (UV and weather-resistant)	30 kg	410 100 014	
			glass-fibre-reinforced plastic (GFRP)	40 kg	410 100 015	
			Metal	35 kg	410 100 009	
		orange (RAL 2000)	PVC - plastic (UV and weather-resistant)	30 kg	410 100 013	
			glass-fibre-reinforced plastic (GFRP)	40 kg	410 100 007	
		Stainless steel	Stainless steel	40 kg	410 100 010	
		TH2	Telephone sound protection hood	Stainless steel	3,5 g	410 100 020
				yellow	PVC - plastic (UV and weather-resistant)	3,5 g



wFT3-IP weather-proof VoIP telephone

- Well-designed weather-proof VoIP telephone
- For universal applications, resistant to high humidity, maritime climates, etc.
- High degree of protection IP 65
- Impact-resistant polycarbonate housing
- Housing colours yellow, red, grey and black
- Can be used as a desk-mounted or wall-mounted telephone
- Intelligent and user-friendly menu structure
- Standard H.323, SIP, TSIP, SIPS protocols
- Power over Ethernet power supply
- Available with armoured or spiral cord as an option
- Illuminated keypad/pixel-based illuminated LCD display
- Multilingual menu navigation
- Receiver can be securely fixed with stabiliser bracket

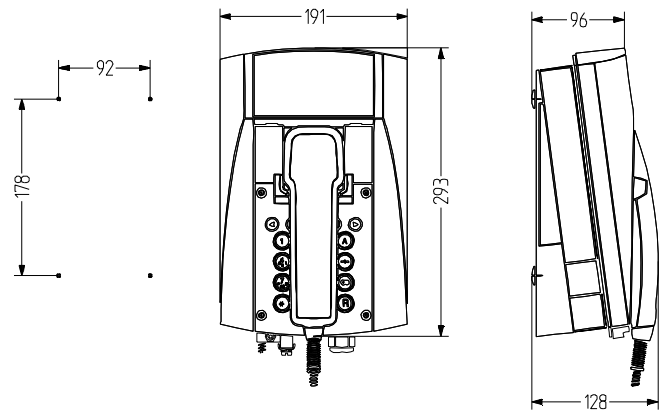

wFT3-IP

TECHNICAL DATA

Tone ringing volume	95 dB
Connection	2× RJ45 ports 10/100 BASE-T Ethernet LAN
Echo compensation	G.168
Housing	Polycarbonate black, black/red, black/grey or black/yellow
Operating temperature	-20 °C / +60 °C
Degree of protection	IP65
Current supply	Power over Ethernet as per IEEE 802.3af
Technology	VOIP
Weight	2,3 kg
Display	128 × 64 Pixel
General	H.323 version 4 incl. H.225, H.235, H.245 and RAS gatekeeper routed signalling, H.450 Session Initiation Protocol (SIP), RTP, SRTP
RTCP	Real time control protocol – first level of 'quality of service'
DTMF	H.245 'alphanumeric' or 'single type'
VoIP features	H.245 fast connect en-bloc dialling overlapped sending
Encryption	Encrypted password authentication as per H.235
Quality of service	Prioritisation of IP packets over TOS and Diffserv, VLAN priority as per IEEE 802.1p/802.1p
Speech codes	G.711 A-law/μ-law (64 kbps), G.723.1 (5,3 kbps), G.729A (16 kbps)
Access	using web browser with HTML Password-protected with secure authentication
Connections for trouble-shooting	Log and trace files, interface status indicators and ping connection test for internet protocol sending of SNMP traps

Update	Saving and reading of configuration, boot code and firmware update by means of HTML upload and automatic update using update server
DSL Zugang	PPPoE protocol
VPN	Tunnelling with PPTP encryption with MPPE
NAT	Network address translation – for translating official IP addresses into unofficial addresses and vice versa
DHCP	Dynamic host configuration protocol – IP interface settings
ICMP	Internet control message protocol – for ping tests
Ring tone generation	Automatic generation of ring tone as per European and US standards
Call switching	Call transfer, in all common variants: with/without enquiry, before/after answering, etc.
Call forwarding	Call diversion/redirection
Hold	Call hold/retrieve
Call waiting	Call waiting, including signalling of second call information
Message	Display on telephone indicating that there is a message
Name Display	for signalling the name which is to be displayed
Conference	with 3 subscribers, including external subscribers
Telephone number identification	displays calling numbers
Multiple entries	maximum of 6 entries
Directory	local, integration or external database
Time	extremely accurate time information thanks to access to time server



ORDER DATA

Cord	Housing colour	Order number
Coiled cord	black/red	410 350 200
	black	410 350 000
	black/grey	410 350 300
	black/yellow	410 350 100
Armoured cord	black/red	410 360 200
	black	410 360 000
	black/grey	410 360 300
	black/yellow	410 360 100

ACCESSORIES

Type	Type of accessory	Order number
STB	Stabiliser bracket	410 400 900
RJ45	weather-proof LAN connector	410 410 900

WIND-IP weather-proof VoIP telephone

- For universal applications, resistant to high humidity, maritime climates, etc.
- (closed) & IP 65 (open)
- Impact-resistant polycarbonate housing
- Transparent protective door, eye-catching housing colour
- Standard protocol SIP (RFC3261)
- Integrated relay contact
- With visual LED call indicator
- Power over Ethernet or 24–48 V DC
- Visual-audible secondary sounder can be connected
- For wall mounting



TECHNICAL DATA

Tone ringing volume	90 dBDoor open: ~90 dB (A) at 1 m; door closed: ~65 dB (A) at 1 m
Power requirement	1,3 W
Connection	RJ45 port (10/100 Mbit/s)
Transportation/storage temperature	-40 °C / 70 °C
Housing	Polycarbonate yellow
Type of mounting	any
Cable entry	2× cable glands M16 × 1.5 for cable diameter of 5–9 mm
Operating temperature	-40 °C / +55 °C
Degree of protection	IP65 & IP66
Current supply	Power over Ethernet as per IEEE 802.3af or 24–48 V DC
Relay switching capacity	Bis zu 30 V AC oder 60 V DC 2 A < 30 V DC 1 A < 30 V DC 1 A < 30 V AC
Technology	VOIP
Protocol	SIP
Weight	2,3 kg (incl. bracket)
Mouthpiece	Electret microphone
Receiver	dynamic receiver

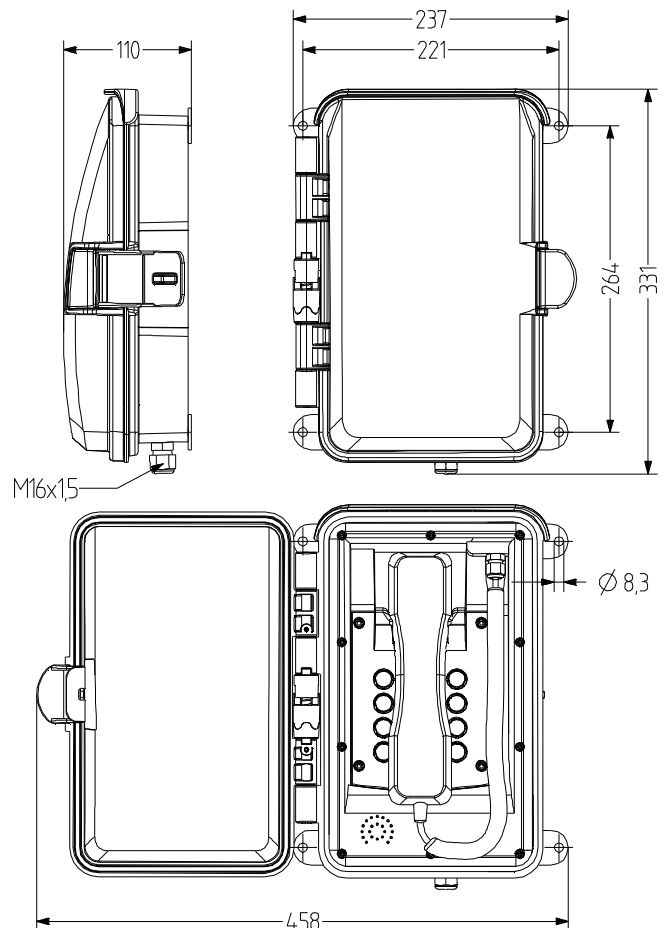

wIND-IP

ORDER DATA

Housing colour	Order number
yellow	410 750 000



VS2



TH1



TH2

ACCESSORIES



Type	Type of accessory	Colour	Housing material	Weight	Order number		
VS2	Visual-audible telephone call signalling sounder	black (RAL 9005)orange		935 g	410 201 005		
		black (RAL 9005)red		935 g	410 202 005		
		black (RAL 9005)clear		935 g	410 204 005		
		black (RAL 9005)blue		935 g	410 205 005		
		black (RAL 9005)green		935 g	410 206 005		
TH1	Telephone sound protection hood	yellow (RAL 1023)	PVC – plastic (UV and weather-resistant)	30 kg	410 100 012		
			glass-fibre-reinforced plastic (GFRP)	40 kg	410 100 008		
			Console (sheet steel, powder-coated)	17 kg	410 100 011		
			Metal	35 kg	410 100 006		
		red (RAL 3020)	PVC – plastic (UV and weather-resistant)	30 kg	410 100 014		
			glass-fibre-reinforced plastic (GFRP)	40 kg	410 100 015		
			Metal	35 kg	410 100 009		
		orange (RAL 2000)	PVC – plastic (UV and weather-resistant)	30 kg	410 100 013		
			glass-fibre-reinforced plastic (GFRP)	40 kg	410 100 007		
			Stainless steel	40 kg	410 100 010		
		TH2	Telephone sound protection hood	yellow	PVC – plastic (UV and weather-resistant)	3,5 g	410 100 030
					Stainless steel	3,5 g	410 100 020

VS2 weather-proof visual-audible telephone call signalling sounder

- Weather-proof visual-audible telephone call signalling sounder
- Several tones/intermittent tone frequencies can be selected
- Die-cast aluminium housing
- High degree of protection IP 66
- Mains power supply (230 V AC)
- For universal use in harsh ambient conditions
- Makes a telephone call more noticeable
- 5 lens colours can be selected



TECHNICAL DATA

audible signal transmitter	Piezo disc
visual signal transmitter	Xenon flashtube with 3 J 230 V AC +/-10%
Call pause bypass	4 s
Tone ringing volume	95 dB
Ringing frequency	16 - 54 Hz
Input impedance	bei 25 Hz $Z \geq 8 \text{ k}\Omega$ bei 50 Hz $Z \geq 4 \text{ k}\Omega$
Pause duration	$\geq 30 \text{ min.}$
Housing	Die-cast aluminium black (RAL 9005)
Lens	Polycarbonate, orange, red, clear, blue or green
Type of mounting	Wall mounting
Cable entry	2xM20x1,5, 5-9mm
Connection technology	up to 1.5 mm ² single or fine wire
Strobe/flash frequency	2-4 Hz
Tone	4 Tones, Two tones or Three tones can be selected with DIP switch
Duty cycle	$\leq 30 \text{ min.}$
Operating temperature	-20 °C / +60 °C
Degree of protection	IP66
Supply voltage	0 V DC - 48 V DC 48 V DC - 63 V DC
Ringing alternating current	24 V AC - 85 V AC 24 V AC - 80 V AC
Insulation class	I
Weight	935 g

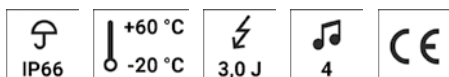
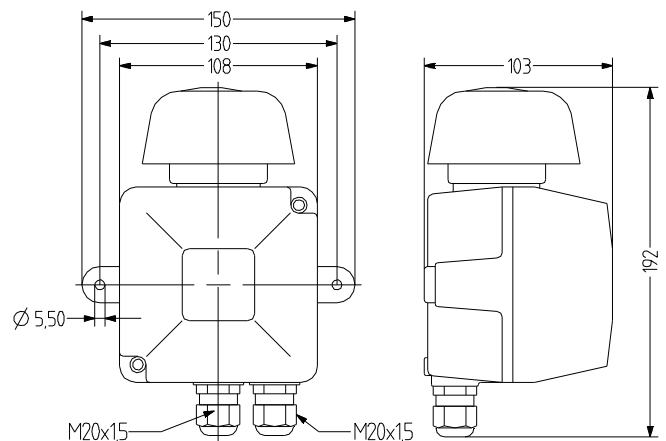

VS2

ORDER DATA

Lens colour	Order number
orange	410 201 005
red	410 202 005
clear	410 204 005
blue	410 205 005
green	410 206 005



IC weather-proof analogue intercom terminal

- Analogue intercom telephone with hands-free kit in stainless-steel housing
- Vandalism-proof, no receiver
- Can be integrated into analogue private branch exchange systems
- Integrated relay enables switching actions (e.g. door closure, signalling)
- Models with 1 or 3 speed code dialogue keys
- Surface-mount or panel-mount models
- Integrated call display
- High degree of protection IP66
- Integrated cover/sabotage contact



TECHNICAL DATA

Tone ringing volume 80 dB

Operating temperature -40 °C / +60 °C

Degree of protection IP66

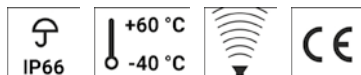

IC

ORDER DATA

Number of keys	Housing	Order number
1	with	410 500 000
	without	410 500 100
3	with	410 510 000
	without	410 510 100



EP2 weather-proof additional earpiece set

- Enables other people to follow a telephone conversation
- Reduction of loud ambient noise during a telephone conversation
- Degree of protection IP 54
- Set contents, Additional earpiece with dynamic receiver, Spiral cord and cable gland, Bracket for attaching to the telephone



TECHNICAL DATA

Connection cord	Coiled cord, 2 wires
Housing	Polyurethane elastomer blue
Cable entry	M20 x 1.5 cable gland
Operating temperature	-20 °C / +60 °C
Degree of protection	IP54
Weight	200 g
Receiver	dynamic receiver

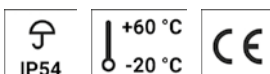
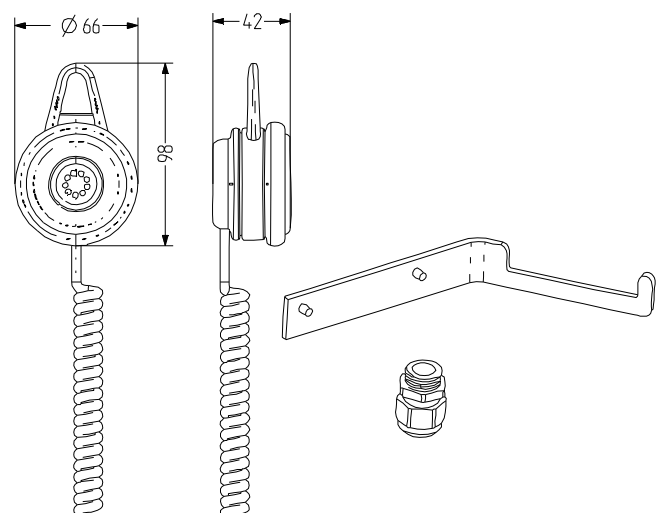

EP2

ORDER DATA

Description	Order number
Additional earpiece set	410 200 002



HS2 weather-proof headset kit

- Weather-proof headset
- Reduction of loud ambient noise during a telephone conversation
- Facilitates communication during activities involving both hands
- Set contents: Headset with dynamic receiver, 14m connecting cord, Bracket for attaching to the telephone



TECHNICAL DATA

Connection cord	14 m connecting cord
Housing	other
Cable entry	M20 × 1.5 cable gland
Operating temperature	-10 °C / +55 °C
Degree of protection	IP66
Weight	410 g
Mouthpiece	noise-compensating close-range electret microphone
Receiver	dynamic receiver

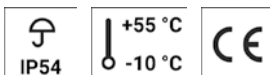

HS2

ORDER DATA

Description	Order number
Headset kit	410 200 001



LS2 weather-proof loudspeaker set

- Weather-proof loudspeaker with plastic housing
- For relaying the ringer sound and the telephone conversation
- Adjustable volume, high degree of protection IP 66
- Set contents: Dynamic loudspeaker, Cable gland for inserting the loudspeaker cable into the telephone



TECHNICAL DATA

Housing	Polyamide 12 black (RAL 9005)
Type of mounting	Wall mounting or Ceiling mounting
Cable entry	Cable gland M20x1,5
Connection technology	bis 2,5 mm ²
Operating temperature	-25 °C / +60 °C
Degree of protection	IP54
Insulation class	II
Weight	1,1 kg
audible signal transmitter	Loudspeaker
Tone ringing volume	93 dB Tone ringing volume / 81 dB speakerphone/hands free functionality
Nominal load	0,300 W
Nominal impedance	45 Ω

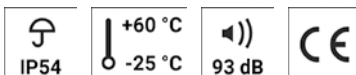

LS2

ORDER DATA

Description	Order number
weather-proof loudspeaker set	410 200 003



TCR weather-proof telephone switch relay

- Weather-proof telephone connecting relay
- Potential-free switching contact for controlling a visual or audible signalling device
- Robust aluminium housing, grey
- Call break bypass and ringing alternating current can be individually adjusted
- Degree of protection IP 55



TECHNICAL DATA

Transportation/storage temperature -30 °C / +70 °C

temperature

Type of mounting any, cable gland preferably not at top

Duty cycle 100 %

Operating temperature -20 °C / +60 °C

Degree of protection IP55

Insulation class I

Weight 750 g

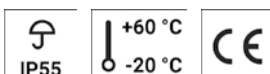
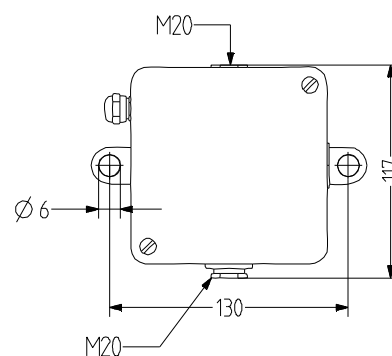
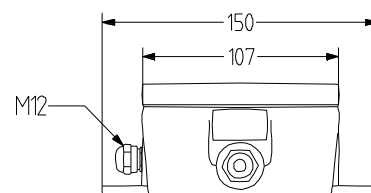

TCR

ORDER DATA

Description	Order number
Weather-proof telephone switch relay	410 100 200



TH1 Telephone sound protection hoods

- Suitable for all types of telephone
- For better audibility of telephone conversations in noisy ambient conditions
- Inner lining of perforated sheet steel
- Excellent sound absorption >25 dB (A) in 1 m
- Various housing colours
- Available housing materials
- GFRP – glass-fibre-reinforced plastic
- PVC – plastic, UV and weather-resistant
- Hot-dip galvanised sheet steel, powder-coated
- Stainless steel
- Console available as an option



TECHNICAL DATA

Sound absorption	bis 25 db (A) in 1 m
Insulating material	Rockwool RAF-SE
Housing	galvanised sheet steel, Stainless steel, glass-fibre-reinforced plastic (GFRP), Plastic (hard PVC, UV and weather-resistant) and Console (sheet steel, powder-coated) yellow (RAL 1023), orange (RAL 2000), red (RAL 3020) or Stainless steel
Weight	35 kg

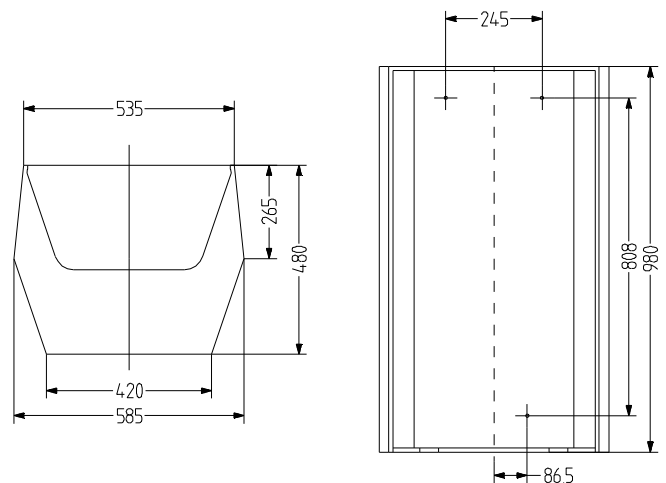

TH1

ORDER DATA

Type	Housing material	Housing colour	Order number
TH1	PVC - plastic (UV and weather-resistant)	orange	410 100 013
		yellow	410 100 012
		red	410 100 014
	Stainless steel	Stainless steel	410 100 010
		glass-fibre-reinforced plastic (GFRP)	orange
	yellow		410 100 008
	red		410 100 015
	Metal	yellow	410 100 006
		red	410 100 009
TH1C	Console (sheet steel, powder-coated)	yellow	410 100 011



TH2 Telephone sound protection hood

- Telephone protection hood for indoor and outdoor applications
- Protects the telephone against environmental influences (rain, snow, dirt, dust, etc.)
- Various housing colours



TECHNICAL DATA

Housing	PVC - plastic (UV and weather-resistant) and Stainless steel yellow
Weight	3,5 g



TH2

ORDER DATA

Type	Housing material	Order number
TH2-P	PVC - plastic (UV and weather-resistant)	410 100 030
TH2-S	Stainless steel	410 100 020



General technical information

Degrees of protection

The degrees of protection set out by standard EN 60529 provide information about the level to which electrical equipment – in our case signalling devices – is protected against the effects of solid foreign objects and against the ingress of liquid by the casing or covers.

The table below provides an overview of what the IP degree of protection numbers mean and how they are put together:

The degrees of protection are indicated by a code which always consists of the two letters 'IP' plus two numbers that represent the level of protection. The most common degrees of protection given to Auer Signal products are IP 65, IP 66 and IP 67.

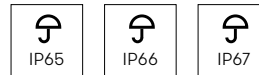

First number

Protection against foreign objects

0 NO PROTECTION
No special protection stopping people directly touching active or moving parts; no protection for the equipment against the ingress of solid foreign objects

1 PROTECTION AGAINST LARGE FOREIGN OBJECTS

Protection against the ingress of solid foreign objects with a diameter of more than 50 mm, e.g. hands

2 PROTECTION AGAINST MEDIUM-SIZED FOREIGN OBJECTS

Protection against the ingress of solid foreign objects with a diameter of more than 12 mm, e.g. fingers

3 PROTECTION AGAINST SMALL FOREIGN OBJECTS

Protection against the ingress of solid foreign objects with a diameter of 2.5 mm, e.g. tools, wires

4 PROTECTION AGAINST GRANULAR FOREIGN OBJECTS

Protection against the ingress of solid foreign objects with a diameter of more than 1 mm, e.g. fine tools, small wires

Second number

Protection against liquid

0 NO SPECIAL PROTECTION

1 PROTECTION AGAINST DRIPPING WATER - FALLING VERTICALLY

Dripping water falling vertically should not have a harmful effect

2 PROTECTION AGAINST DRIPPING WATER - FALLING AT AN ANGLE

Dripping water falling at any angle up to 15 degrees to the vertical should not have a harmful effect.

3 PROTECTION AGAINST SPRAYING WATER

Dripping water falling at any angle up to 60 degrees to the vertical should not have a harmful effect

4 PROTECTION AGAINST SPLASHING WATER

Water splashing against the equipment from all directions should not have a harmful effect

5 PROTECTION AGAINST DUST DEPOSITS

Fully protected against dust deposits:
The ingress of dust is not completely ruled out, but does not impair the functionality of the device

6 PROTECTION AGAINST INGRESS OF DUST

Fully protected against the ingress of dust

5 PROTECTION AGAINST WATER JETS

A jet of water from any direction should not have a harmful effect

6 PROTECTION AGAINST FLOODING

A harmful amount of water should not enter the equipment in the event of temporary flooding

7 PROTECTION IN THE EVENT OF IMMERSION

A harmful amount of water should not enter the equipment when it is immersed in water under the specified pressure and time conditions

8 PROTECTION IN THE EVENT OF DEEP IMMERSION

A harmful amount of water should not enter the equipment when it is immersed under water

TECH-
NICAL
INFOR-
MATION

Standards and certification marks

UL CERTIFICATION

Given that Auer Signal has a global market presence, the majority of the company's signalling equipment is also certified in line with UL standards.

Plus, as a member of the 'Client Test Data Program', Auer Signal is also authorised to conduct UL-related tests in its own laboratory. UL accepts the results of such tests on a provisional basis, but then periodically repeats the tests to check the quality of the results.



UL is the locally established certification for devices specifically on the US market. Although UL certification is not a fixed requirement in particular outside of America, a user of a device with

UL certification can be sure that it meets incredibly stringent safety standards because UL has a stronger focus on safety-related aspects than European standards.

As part of UL certification, devices have to be tested by qualified testers and inspectors are sent out to device manufacturers four times a year under the scope of follow-up services to ensure that the prescribed manufacturing methods and material specifications are being upheld.

If the UL mark is preceded by the letter C, it indicates that the device has also been tested in line with the standards set out by the CSA (Canadian Standards Association) and has also been certified for use in Canada."



The list below provides an explanation of the device classifications according to UL:

Type 1

Indoor use primarily to provide protection against contact with the enclosed equipment and against a limited amount of falling dust/dirt

Type 2

Indoor use to provide a degree of protection against a limited amount of water and dust

Type 3

Outdoor use to provide a degree of protection against windblown dust and rain; the device is undamaged by the formation of ice on the enclosure

Type 3R

Outdoor use to provide a degree of protection against rain; the device is undamaged by the formation of ice on the enclosure

Type 4

Either indoor or outdoor use to provide a degree of protection against rain, splashing water and hose-directed water; the device is undamaged by the formation of ice on the enclosure

Type 4X

Either indoor or outdoor use to provide a degree of protection against rain, splashing water and hose-directed water; the device is undamaged by the formation of ice on the enclosure; resists corrosion

Type 6

Indoor or outdoor use to provide a degree of protection against entry of water during temporary submersion/flooding at a limited depth; the device is undamaged by the external formation of ice on the enclosure

Type 12

Indoor use to provide a degree of protection against dust, dirt, fibre flyings, dripping water and external condensation of non-corrosive liquids

Type 13

Indoor use to provide a degree of protection against lint, dust seepage, external condensation and spraying of water, oil and non-corrosive liquids

CE MARKING

The CE marking is the manufacturer's declaration – in the form of a conformity declaration – that the product meets all of the applicable European directives and the safety requirements contained within them.



ATEX

The ATEX logo indicates that a product is permitted for use in potentially explosive atmospheres in accordance with the European ATEX Directive. The product itself has a test number and detailed information about the certification on its label.

AS INTERFACE

The AS-INTERFACE logo shows that a product can be integrated into an AS-Interface fieldbus system.

Explosion-proof devices provide protection in atmospheres with flammable gases, vapours, mists or dusts.

Auer Signal developed its first explosion-proof signalling equipment more than a quarter of a century ago.

The company's product portfolio includes visual, visual-audible and audible signalling equipment that is explosion-proof, and explosion-proof telephones have been sold with success on the global market for over 25 years now.

ABOUT EXPLOSION PROTECTION

Flammable gases, vapours, mists and dusts are formed within the chemical and petrochemical industry, i.e. from the extraction to the processing of crude oil and natural gas, as well as in many other industrial sectors that work with the production, processing, transportation or storage of flammable gases, liquids and dusts. These substances mix with oxygen in the atmosphere, creating a potentially explosive atmosphere. In the event of ignition, explosions could be caused, which might result in serious injury to people and damage to property.

As a general rule, three elements are required for an explosion to be caused –these are depicted in the internationally recognised explosion triangle symbol:



EXPLOSION-PROOF SIGNALLING EQUIPMENT

If an industry is working with a potentially explosive atmosphere, all potential sources of ignition need to be identified and switched off. As a standard signal beacon could trigger an explosion in a potentially explosive atmosphere should a fault occur, only special explosion-proof signalling equipment (Ex devices) should be used in this type of atmosphere. The obvious

assumption that an explosion-proof signalling device would be protected from the consequences of an explosion is incorrect. In actual fact, the explosion-proof signalling device should not act as a source of ignition in the event of a fault and therefore not cause an explosion outside of the explosion-proof device.

REGULATIONS FOR EXPLOSION-PROOF SIGNALLING EQUIPMENT

Relevant protective regulations are in place to prevent the risk of explosions. These come in the form of laws, directives and standards, all of which guarantee high safety standards. With Directive 94/9/EC, the EU laid down the ATEX Directive (currently 2014/34/EU), which is derived from the French '*atmosphère explosible*' and now brings together all of the different regulations that existed previously.

CERTIFICATION OF EXPLOSION-PROOF SIGNALLING EQUIPMENT

Explosion-proof signalling equipment that complies with the ATEX Directive has to be tested and certified by independent authorities and testing institutes (e.g. PTB Braunschweig, DMT Essen, etc.) before it is manufactured and sold.

DESIGNATION AND CLASSIFICATION OF EXPLOSION-PROOF SIGNALLING EQUIPMENT

Below you will find an overview of the designations for the classification of typical explosion-proof signalling equipment from Auer Signal along with an explanation of the meanings behind them:

Potentially explosive atmospheres – dust

Labelling of electrical equipment as per

EC Directive 2014/34/EU – ATEX

CE 0102  II 2D tD T80 °C

1

2

3

4

5

1



COMPLIANCE WITH
EU DIRECTIVE(S)

5

T80 °C

MAXIMUM PERMITTED
SURFACE TEMPERATURE

2

0102

OFFICIAL TESTING
AUTHORITY

testing authority	Country	Identification number
TÜV-A	Austria	0408
PTB	Germany	0102
EXAM	Germany	0158

CLASSES AND GROUPS ACCORDING TO NEC
500: TYPICAL DUSTS, LINT, FIBRES

Class II	Class III
Metal dust/Group E	
Coal dust/Group F	Fibres/lint
Grain dust/Group G	

TECH-
NICAL
INFOR-
MATION

3

II 2D

CONDITIONS IN POTENTIALLY EXPLOSIVE ATMOSPHERES

Flammable substances	Temporary behaviour of the flammable substance in the potentially explosive atmosphere	Classification of potentially explosive atmospheres			Labelling required for applicable equipment according to CENELEC	
		CENELEC/IEC	US NEC 505	US NEC 500	Device group	Device category
Dusts	Present continuously, for long periods or frequently	Zone 20	---	Class II Division 1	II	1D
	Occur occasionally	Zone 21	---		II	2D (or 1D)
	Not likely to occur – if so, infrequently or for a short period only	Zone 22	---		II	3D (or 2D or 1D)
Dust	---	Mining Mining	---	Mining ---	I I	M1 M2 (or M1)

4

tD

TYPES OF IGNITION PROTECTION

Type of ignition protection	Symbol	Labeling	Protection principle	Zone	CENELEC IEC FM/UL	Application
General requirements				All Class II, Div. 1/2	IEC 61241-0 UL 1604	All applications
Protection by enclosure		tD	Potentially explosive atmosphere is kept away from the source of ignition; there is a limit on the temperature.	20, 21 oder 22 20, 21 oder 22 Class II, Div. 1	EN 50281-1-1 IEC 61241-1-1 UL 1203	Control, command and signalling equipment, beacons, engines, junction boxes, enclosure
Pressurised enclosure		pD	Potentially explosive atmosphere is kept away from the source of ignition.	21 or 22 21 or 22 Class II, Div. 1/2	EN 50281-4 IEC 61241-2 NFPA 496	Switch and control cabinets, engines, measurement and analysis equipment, computers
Intrinsic safety		iD	Energy limitation of sparks and temperatures	20, 21 or 22 20, 21 or 22 Class II, Div. 1	EN 50281-5 IEC 61241-11 FM 3610/UL 913	Measurement and control technology, sensors, actuators, instrumentation
Special encapsulation		mD	Potentially explosive atmosphere is kept away from the source of ignition.	20, 21 or 22 20, 21 or 22 ---	EN 50281-6 IEC 61241-18	Relay and engine coils, electronics, solenoid valves, connection systems
Non-incendive		[NI]	Prevention of sparks and temperatures	Class II, Div. 1	FM 3611/UL 1604	
Dust-proof			Transferral of explosion outside not possible	Class II, Div. 2	FM 3611/UL 1604	

Potentially explosive atmospheres – gas

Labelling of electrical equipment
as per EC Directive 94/9 – ATEX

CE 0102 **Ex** II2G EEx de IIC T6

1 2 3 4 5 6 7 8

1 **CE** COMPLIANCE WITH
EU DIRECTIVE(S)

4 **E** AS PER DIRECTIVE 94/9/EG
(ATEX)

2 **0102** OFFICIAL TESTING
AUTHORITY

5 **Ex** EXPLOSION-PROOF EQUIPMENT

testing authority	Country	Identification number
TÜV-A	Austria	0408
PTB	Germany	0102
EXAM	Germany	0158

3 **II2G** CONDITIONS IN POTENTIALLY EXPLOSIVE ATMOSPHERES

Flammable substances	Temporary behaviour of the flammable substance in the potentially explosive atmosphere	Classification of potentially explosive atmospheres			Labelling required for applicable equipment according to CENELEC	
		CENELEC / IEC	US NEC 505	US NEC 500	Device group	Device category
Gases, vapours	Present continuously, for long periods or frequently	Zone 0	Class I Zone 0	Class I Division 1	II	1G
	Occur occasionally	Zone 1	Class I Zone 0		II	2G (or 1G)
	Not likely to occur – if so, infrequently or for a short period only	Zone 2	Class I Zone 0	Class I Division 2	II	3G (or 2G or 1G)
Methane	---	Mining Mining	---	Mining ---	I I	M1 M2 (or M1)

8 **T6** TEMPERATURE CLASSES AND MAXIMUM PERMITTED SURFACE TEMPERATURE OF EQUIPMENT ACCORDING TO CENELEC/IEC/NEC 505 UND NEC 500





450° C	T1						
300° C		T2					
200° C			T3				
135° C				T4			
100° C					T5		
85° C						T6	
0° C							
CENELEC	T1	T2	T3	T4	T5	T6	
IEC							
NEC 505							

CLASSES AND GROUPS ACCORDING TO NEC 500: TYPICAL GASES

Class I	Mining
Acetylene/Class A	
Hydrogen/Class B	Methane
Ethylene/Class C	
Propane/Class D	

6

de TYPES OF IGNITION PROTECTION

Type of ignition protection	Symbol	Labeling	Protection principle	Zone	CENELEC IEC FM/UL	Application
General requirements				all	EN 60079-0 IEC 60079-0 FM 3600/UL 2279	all
Flame-proof enclosure		EEx d Ex d AEx d	Transferral of explosion outside not possible	1 or 2 1 or 2	EN 50018 IEC 60079-1 FM 3615/UL 2279	Control, command and signalling equipment, control systems, engines, power electronics
Increased safety		EEx e Ex e AEx e	Prevention of sparks and temperatures	1 or 2 1 or 2 Class 1, Zone 1	EN 50019 IEC 60079-7 FM 3600/UL 2279	Junction boxes, enclosure, engines, beacons, terminals
Intrinsic safety		EEx i Ex i [IS]	Energy limitation of sparks and temperatures	0, 1 oder 2 0, 1 oder 2 Class I, Div. 1	EN 50020, EN 50039 IEC 60079-11 FM 3610/UL 2279	Measurement and control technology, sensors, actuators, instrumentation
Pressurised enclosure		EEx p Ex p	Potentially explosive atmosphere is kept away from the source of ignition.	1 or 2 1 or 2 Class I, Div. 1/2	EN 50016 IEC 60079-2 FM 3620/NFPA 496	Switch and control cabinets, engines, measurement and analysis equipment, computers
Special encapsulation		EEx m Ex m AEx m	Potentially explosive atmosphere is kept away from the source of ignition.	1 or 2 1 or 2 Class I, Zone 1	EN 50028 IEC 60079-18 FM 3600/UL 2279	Relay and engine coils, electronics, solenoid valves, connection systems
Oil filled		EEx o Ex o AEx o	Potentially explosive atmosphere is kept away from the source of ignition.	1 or 2 1 or 2 Class I, Zone 1	EN 50015 IEC 60079-6 FM 3600/UL 2279	Transformers, relays start-up controllers, control systems
Sand filled		EEx q Ex q AEx q	Transferral of explosion outside not possible	1 or 2 1 or 2 Class, Zone 1	EN 50017 IEC 60079-5 FM 3600/UL 2279	Transformers, relays, capacitors
Type of ignition protection 'n'		EEx n Ex n AEx n	Different protection principles for Zone 2	2 2 Class I, Zone 2	EN 50021 IEC 60079-15 FM 3600	Only Zone 2 applications
Non-incendive		[NI]	Prevention of sparks and temperatures	-- -- Class I, Div. 1	-- -- FM 3611/UL 1604	
Explosion-proof		[XP]	Transferral of explosion outside not possible	-- -- Class I, Div. 1	-- -- Class I, Div. 1	
Optical radiation		Eex op Ex op	Limit, prevent, etc., transfer of energy from optical radiation	1 or 2 1 or 2	EN 60079-28 IEC 60079-28	Optoelectronic devices, e.g. with optical waveguide

TECH-
NICAL
INFOR-
MATION

7

IIC CLASSIFICATION PER CENELEC/IEC/NEC 505, EXPLOSION SUB-GROUP GASES AND VAPOURS

	T1	T2	T3	T4	T5	T6
I	Methane	--	--	--	--	--
IIA	Ammonia Methane Ethane Propane	Ethyl alcohol Cyclohexan n-Butane n-Hexane	Fuels in general Jet fuel Heating oils	Acetaldehyde	--	--
IIB	Town gas Acrylonitrile	Ethylene Ethylene oxide	Ethylene glycol Hydrogen sulphide	Ethyl ether	--	--
IIC	Hydrogen	Ethyne (acetylene)	--	--	--	Carbon disulphide

Type index

Type	Order No.	Product	Series	Page
AS1	410	Explosion-proof audible telephone call signalling sounder	Explosion-proof Accessories	46
dFT3	410	Explosion-proof analogue telephone	Explosion-proof	36
dFT3-IP	410	Explosion-proof VoIP telephone	Explosion-proof	42
dHH	300	Explosion-proof signal horn	Explosion-proof	24
dHW	320	Explosion-proof signal bell	Explosion-proof	26
dMS	371	Explosion-proof multi-tone alarm sounder	Explosion-proof	18
dSD	335	Explosion-proof LED signal beacon	Explosion-proof	10
dSF	335	Explosion-proof Xenon strobe beacon	Explosion-proof	16
dST	410	Explosion-proof analogue telephone	Explosion-proof	32
dST-IP	410	Explosion-proof VoIP telephone	Explosion-proof	38
dST-MB	410	Explosion-proof analogue telephone	Explosion-proof	34
EP1	410	Explosion-proof additional earpiece set	Explosion-proof Accessories	50
EP2	410	weather-proof additional earpiece set	Weather-proof Accessories	76
HS1	410	Headset kit	Explosion-proof Accessories	52
HS2	410	weather-proof headset kit	Weather-proof Accessories	78
IC	410	weather-proof analogue intercom terminal	Weather-proof Accessories	74
LS2	410	weather-proof loudspeaker set	Weather-proof Accessories	80
mDD	336	Explosion-proof LED signal beacon	Explosion-proof	12
mHPT	301	Explosion-proof signal horn	Explosion-proof	20
mHTG	302	Explosion-proof signal horn	Explosion-proof	22
mMD	337	Explosion-proof LED multi colour beacon	Explosion-proof	14
mTCR	410	Explosion-proof telephone connecting relay	Explosion-proof Accessories	54
TCR	410	weather-proof telephone switch relay	Weather-proof Accessories	82
TH1	410	Telephone sound protection hoods	Weather-proof Accessories	84
TH2	410	Telephone sound protection hood	Weather-proof Accessories	86
wFT3	410	weather-proof analogue telephone	Weather-proof	60
wFT3-IP	410	weather-proof VoIP telephone	Weather-proof	68
wIND	410	weather-proof analogue telephone	Weather-proof	62
wIND-IP	410	weather-proof VoIP telephone	Weather-proof	70
wST	410	weather-proof analogue telephone	Weather-proof	56
wST-IP	410	weather-proof VoIP telephone	Weather-proof	64
wST-MB	410	weather-proof analogue telephone	Weather-proof	58
VS1	410	Explosion-proof visual-audible signalling sounder	Explosion-proof Accessories	48
VS2	410	weather-proof visual-audible telephone call signalling sounder	Weather-proof Accessories	72

Item index

Order No.	Type	Product	Series	Page
300	dHH	Explosion-proof signal horn	Explosion-proof	24
301	mHPT	Explosion-proof signal horn	Explosion-proof	20
302	mHTG	Explosion-proof signal horn	Explosion-proof	22
320	dHW	Explosion-proof signal bell	Explosion-proof	26
335	dSD	Explosion-proof LED signal beacon	Explosion-proof	10
335	dSF	Explosion-proof Xenon strobe beacon	Explosion-proof	16
336	mDD	Explosion-proof LED signal beacon	Explosion-proof	12
337	mMD	Explosion-proof LED multi colour beacon	Explosion-proof	14
371	dMS	Explosion-proof multi-tone alarm sounder	Explosion-proof	18
410	dST	Explosion-proof analogue telephone	Explosion-proof	32
410	dST-MB	Explosion-proof analogue telephone	Explosion-proof	34
410	dFT3	Explosion-proof analogue telephone	Explosion-proof	36
410	dST-IP	Explosion-proof VoIP telephone	Explosion-proof	38
410	dFT3-IP	Explosion-proof VoIP telephone	Explosion-proof	42
410	AS1	Explosion-proof audible telephone call signalling sounder	Explosion-proof Accessories	46
410	VS1	Explosion-proof visual-audible signalling sounder	Explosion-proof Accessories	48
410	EP1	Explosion-proof additional earpiece set	Explosion-proof Accessories	50
410	HS1	Headset kit	Explosion-proof Accessories	52
410	mTCR	Explosion-proof telephone connecting relay	Explosion-proof Accessories	54
410	wST	weather-proof analogue telephone	Weather-proof	56
410	wST-MB	weather-proof analogue telephone	Weather-proof	58
410	wFT3	weather-proof analogue telephone	Weather-proof	60
410	wIND	weather-proof analogue telephone	Weather-proof	62
410	wST-IP	weather-proof VoIP telephone	Weather-proof	64
410	wFT3-IP	weather-proof VoIP telephone	Weather-proof	68
410	wIND-IP	weather-proof VoIP telephone	Weather-proof	70
410	VS2	weather-proof visual-audible telephone call signalling sounder	Weather-proof Accessories	72
410	LS2	weather-proof loudspeaker set	Weather-proof Accessories	80
410	EP2	weather-proof additional earpiece set	Weather-proof Accessories	76
410	HS2	weather-proof headset kit	Weather-proof Accessories	78
410	TCR	weather-proof telephone switch relay	Weather-proof Accessories	82
410	TH1	Telephone sound protection hoods	Weather-proof Accessories	84
410	IC	weather-proof analogue intercom terminal	Weather-proof Accessories	74
410	TH2	Telephone sound protection hood	Weather-proof Accessories	86